

TETRADIS

DESIGNER AND DISTRIBUTOR
OF TELECOMMUNICATIONS SOLUTIONS

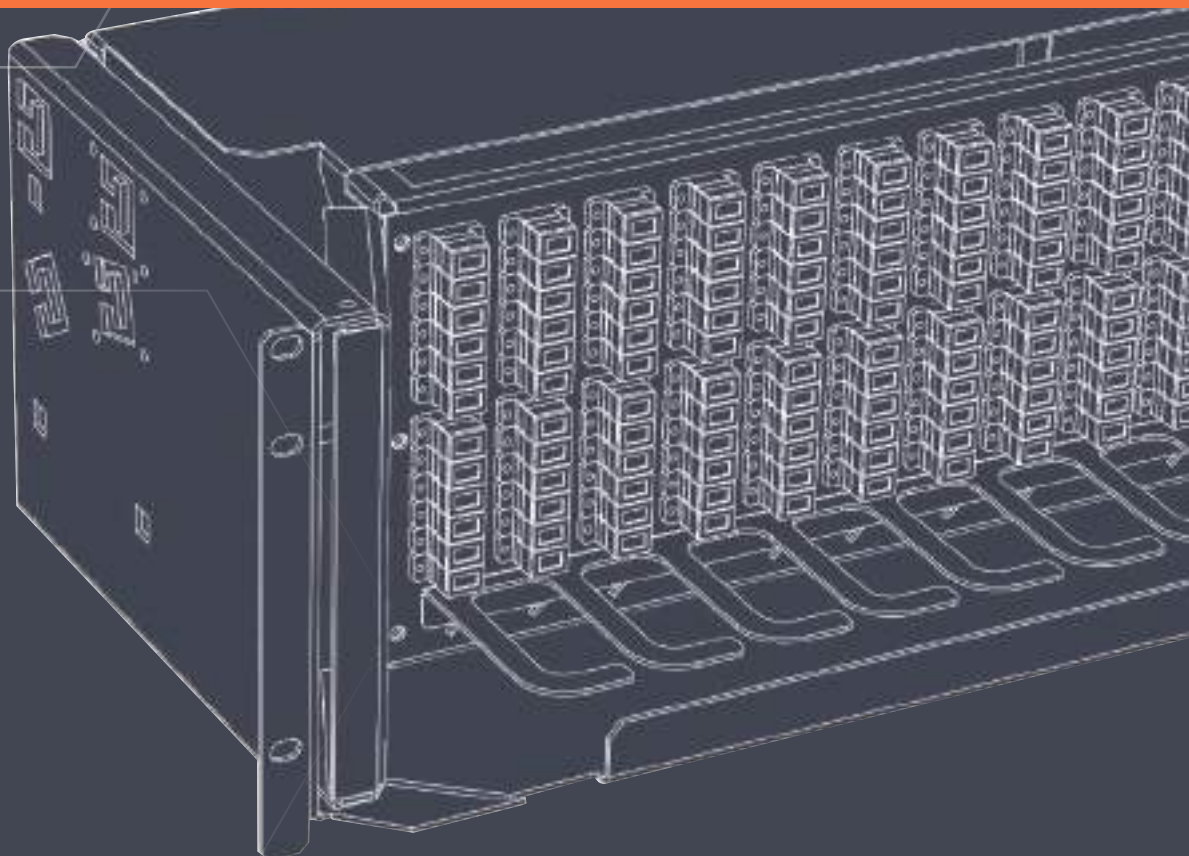

EDITORIAL

Our mission : support you in the deployment of your telecom networks

TETRADIS, actor, distributor, designer recognized on the French national territory turns to the international. Driven by a worldwide craze related to the transfer and storage of data, our market potential continues to grow.

It is quite natural that **TETRADIS** has to evolve his offer dedicated to the needs of all geographical sectors. Innovation, on which **TETRADIS** has based his value proposition, is a guarantee of performance in a constantly moving environment.

The international development of **TETRADIS** is not motivated by relocation. We see a real opportunity to support the needs of telecom players in territories becoming digital.

With 15 years of recognized experience with the largest French players, it is natural today to serve countries in transition to very high speed.

Our R & D department and our **THD Factory** manufacturing unit based in France testify to the commitment of **TETRADIS** to support, in a leading position, the THD, tertiary, industrial, operator and community projects.

Today we cover 25 foreign territories and reinforce our skills every day to meet your needs.

Our strategy, however, remains strongly focused on progressive capillarity: the market can be global but the approach is local (country by country, or group of countries by group of countries). This small steps Policy help to consolidate the locations while ensuring our service.

Through the elements of this brochure let us present you a non-exhaustive range of products and innovative solutions answering your expectations of telecom deployments.



FTTH

ULTRA-HIGH SPEED BROADBAND

COPPER AND OPTICAL NETWORKS

SUMMARY

TETRADIS THD FACTORY	THD FACTORY	Page 4	PARTENAIRES THD FACTORY	Services and Partners TETRADIS	Page 24
	Development and manufacture MADE IN FRANCE			Cabinet GR3 (COMMSCOPE)	Page 25
	Proximity manufacturing			Range FIST GCO2 (COMMSCOPE)	Pages 26-27
	Label of excellence			Range TENIO (COMMSCOPE)	Page 28
	GRADE B1 CERTIFICATION	Page 5		Mini-OTE - DROP Cable (COMMSCOPE)	Page 29
	Standards and performance grades			Range BUDI (COMMSCOPE)	Page 30
	PM in street cabinet (Modul'O HD)	Page 11		Optical Terminal Outlet	Page 31
	Pivoting Optical Shelves (TOP 1U, 3U et 4U)	Page 12		Range BPE-O (3M)	Pages 32-33
	Sliding Optical Shelves (TOM 1U, 1.5U, 2U et 3U)	Page 13		Range RFO NG II (3M)	Page 34
	Secure Optical Box (COS)	Page 14		PBPO and PBPO-C (3M)	Page 35
	Pivoting optical trays & optical box (POP,COD)	Page 15		MDUO-C (3M)	Page 36
	Fan-Out (T-FanO)	Page 16		Instrumentation measure (EXFO) and iOLM (EXFO)	Page 37
	Tooling Box (Optitool, Optibox)	Page 17		MaxTester DSL, MaxTester OTDR, FTB-1 iOLM, FTB-2 PON iOLM & Fiber Guardian	
	Adapters, pigtails and patchcords Monomode	Pages 18-19		Video inspection FIP-400 and optical sonde P5000i	Page 38
	Adapters, pigtails and patchcords Multimode	Pages 20-21		Splicing by fusion FSM-12S, 22S and 70S (FUJIKURA)	Page 39
PLC Splitter	Page 22	Liftplaq	Page 40		
Preconnect cable Break-Out	Page 23	Fixing accessories overhead networks (SM-CI)	Page 41		
		Tracer of cables and detector markers	Page 42		
		Glossary	Pages 44-45		



THE EXPERIENCE

TETRADIS,
Manufacturer and trader
with *great added value*, specialized in
telecommunications on optical
fiber and copper.

TETRADIS is specialized in the manufacture and design of telecommunications equipment.

The foundation of **TETRADIS** is based on technical foundations and field experience. The sales engineers of the company guide you and advise you in choosing the products best suited to your needs.

We do everything we can to bring you much more than a general distributor. All our technical skills accompany you throughout your project, **from the feasibility study to the certification, through the implementation.**

In addition, we want to give you the opportunity to access technical information, constantly evolving. To do this, we are at your disposal to answer all your questions.

A TEAM OF EXPERTS AT YOUR SERVICE :



Sales Engineers



Research unit R&D



Quality Department

THE SAVOIR-FAIRE

TETRADIS is a dynamic company, specialized in **ultra-high-speed broadband interconnection solutions.**

Leader on TELECOM network, VDI cabling, and VIDEO network, we offer you all products among **5 products families** :

- **OPTICAL AND COPPER CABLES**
- **PASSIVE COMPONENTS**
- **ACTIVE EQUIPMENTS**
- **TOOLS AND NETWORK TESTING UNITS**
- **SECURITY**

TRADER

17.000 product references



3.000m² of storage



120 commercial partners



International distribution



MANUFACTURER



Production Made in France



2 filed patents



16.000 annual production



1 integrated study office

As a Manufacturer and Distributor, **TETRADIS** is committed to providing its customers with quality products, respecting the international standards of the sector.

Thanks to a rigorous selection of our suppliers, each product is tested and controlled so that its efficiency is optimal in the field.
Our distributor products meet CE and RoHS standards and are tested according to the IEC standards of electronics.
TETRADIS products are tested before each factory release for efficient and accurate deployment.



— *The quality by TETRADIS*

- *Products tested and controlled*
- *Requirements for our business partners*
- *Control of processes and circuits*
- *Certification and compliance*

FOCUS

The product developed under « **TETRADIS THD Factory** » label are made in France, in our workshop in Saint-Quentin-Fallavier.

Our first-class optical components are made by our partners to our specifications and performance requirements.

They pursue a **Zero defect objective**.

In addition to ordinary inspections, the certified **Grade B1** components are qualified **100% Interferometry PASS*** with french equipment and are **serially numbered** for complete traceability.

A team assembles the mechanical components of the container (window, box, optic drawers ...) when others incorporate carefully previously qualified components.

In output chain, 100% of our pigtailed integrated into our factory have a serial number associated with a geometric ratio test of the optical face.

For the optical items, this final test consists of a new inspection of the surface quality achieved with digital cameras. If necessary cleaning is performed, to reach excellence.

**The quality of fiber end surface has a significant impact on the resulting performance and durability of the plug. Interferometry is a contactless test providing accurate information on the geometry of the fiber end and the ferrule extremity.*

LABEL OF EXCELLENCE





RESEARCH & DEVELOPMENT UNIT

INNOVATION BY TETRADIS

Thanks to its experience gained over the years, and in order to complete the range of products of the partner manufacturers, **TETRADIS** is now positioned as **Manufacturer** of its own FTTH, VDI and Security solutions.

It is through its Research and Development department, integrated within the **THD Factory in France**, near Lyon, that the company **TETRADIS** designs, develops and assembles the products it imagines. Proud to display the French flag, **TETRADIS** develops and manufactures tailor-made THD solutions for the most demanding customers.



Conception,
development
and assembly



2 patents
filed



Monthly
innovations



Production
Made in France

It is from its manufacturing site in France, that development requests follow a well-oiled process where products are created before your eyes, step by step.

Taking into account the specifications, feasibility study, drafting of paperwork, CAD translation, development of a 3D virtualization, drawing, prototyping, production, customer recipe ... **Every moment is important so that the need for customer be satisfied !**

DEVELOPMENT AND PRODUCTION MADE IN FRANCE



— Services by TETRADIS

- *Listening to needs*
- *Customized accompaniment*
- *Fast and efficient services*
- *Kitting and integration to facilitate deployments*

FOCUS

For end-user satisfaction, we offer an **Integration Service** to all customers. Servers, street cabinet, optical shelves and other components are integrated, as required, upstream of the field deployment.

Fiber closures proposed by standard builders solutions are then integrated with adapters, pigtails and splitters, thus avoiding any handling operation in the field. It is also a guarantee of quality for the customer, who ensures that the components are tested and approved by our quality laboratories, before being put into service for the end customer.

Servers and street cabinets are also integrable and connectable by **TETRADIS** services and adapted to the installer's request. Field coaching is also possible.

INTEGRATION

« *Quality components, customized and controlled ... Ready to connect. »*



TETRADIS also offers a **Kitting Service**, in order to have a better reactivity on the building sites.

This service translates into a precise study of the customer's needs in order to anticipate flows and to simplify logistics management, optimize inventory management and more responsive deployments.

This service accompanies the customer on the site since it receives a single reference grouping several products.

KITTING

« *Several order codes... 1 product only ! Guaranteed effectiveness in the field. »*

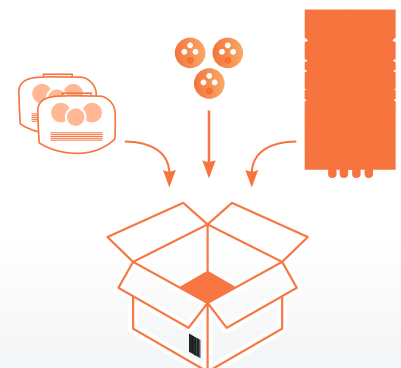



TRAINING



TETRADIS is also a vocational training institution known in the Telecom market. (registered under le n° 82 38 04 004 38*)

To offer you more services, **TETRADIS** provides its customers with a range of equipment in the forefront of technology.

** This registration doesn't imply approval of the French State*

3 SPECIFICATIONS AREAS :



OPTICAL FIBER

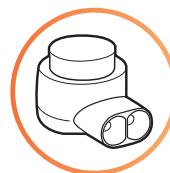

TELECOM



VDI

— Why training by TETRADIS ?

- Advice from experienced technicians
- Ensure a grip of the material
- Show good practices to ensure optimal results
- Entrust basic rules of routine maintenance
- Transfer simple gestures that become autonomous in level 1

FOCUS

RENTING



Thanks of its renting service, TETRADIS offers possibility to all customers to have quality materials on their sites.

With many products references, and especially **Measuring and Splicing** devices such as photometers, reflectometers or fusion splicers, TETRADIS adapts to the constraints of its customers for their equipment rental.

TETRADIS also offers a purchase option, after the rental time of the product, thus offering a preferential rate to its customer.

MAINTENANCE



- **Support** for your equipment at the address of your choice
- Provision of replacement equipment during the period of immobilisation (commitment according to the nature of the contract subscribed)
- **Complete internal checkup to avoid costly intervention**
- Shipment remaining from your equipment closer to your job site
- In the event of a serious defect, shipping at our expense to FUJIKURA Labo Europe
- Supervision of the maintenance actions to be carried out
- Return on site of the equipment thus repaired and guaranteed

THE ACCOMPANYING FOR ALL YOUR PROJECTS

Introducing an optical fiber network as it could be deployed by a collectivity or in a big town, by a telecom operator.
Each product is so detailed, from the outdoor street cabinet to the buried fiber closure, but also component as splicing shelves, cables and outdoor boxes, it is a question of proposing a complete solution dedicated to the very high speed.

FTTH SOLUTION

This solution highlights the products needed for datacenter installation, by an operator or for a company.
We thus find indoor cabinets, active equipments, splicing shelves and cabling equipment. An optimal solution for a performing datacenter.

DATACENTER SOLUTION

Destined to a tertiary use, the products proposed in the VDI solution will allow the telecom installer or the electrician to link the final customer to the multiple network connections needed, telephony, internet or other. RJ45 plugs, electric powerstrips, cabinets and indoor computer cases which are proposed perfectly fit within industrial and tertiary deployment.

VDI SOLUTION

Through this solution, a private company, a public establishment or an installer would have all the video protection equipment, access control and intrusion detection to equip buildings.

SECURITY SOLUTION





PRODUCTS BY TETRADIS

Thanks to its research and integrated research and development department within the THD Factory, **TETRADIS** designs and develops its own products. **TETRADIS** offers you its **own range of products**, of high quality, and whose products are manufactured in France, thought out to optimize the deployment of your networks and assembled in our French factories.

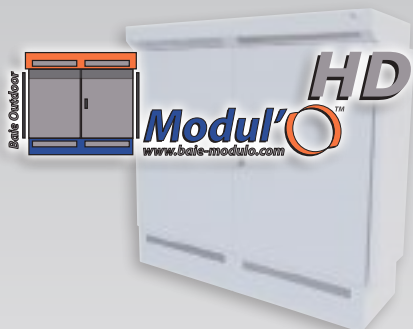

The evolutive and modular **street cabinet** with a bio-climatic designed by TETRADIS.

The manufacture by TETRADIS

Products Made in France

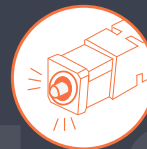

Pigtails and adapter Grade B1 certified

Easily identify the products Made in France and Grade B1, thanks to these pictograms located at the top of the page.



Range of **pivoting optical shelves**, to 24 at 144 adapters. Available with left or right pivot.

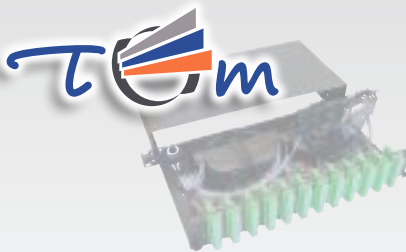

Range of **sliding optical drawers**, the heart of the drawer tilts at 10°. Available for splicing/patching, splitters or coiling.



The optimal **secure optical box** for industrial or building applications with 2 separate compartments. Available in patching/patching, splicing/splicing or splicing/patching.



Range of **universal metal fan-out**. 4 different models to meet multiple configurations.



Range of **pivoting optical trays**, with the heart of the drawer tilted at 10°.



Range of **optical boxes mounted on DIN Rail** with a small footprint and high fiber capacity.



Point of Mutualisation in street cabinet

RANGE MODUL'O HD

The outdoor evolutive cabinet **Modul'O** offers evolutivity and modularity. The distinct functional blocks, offer various possibilities of assembly and use.

This evolutive street cabinet is...

- A street cabinet with Bioclimatic Concept...
- A street cabinet with High Functional...
- A street cabinet with Smart patchcord management...
- A street cabinet with Smart energy management...
- All for many applications

In PM configuration, this street cabinet meets ARCEP specifications with 3 distinct functional areas:

- Right LAT Part: Subscriber AR Area
- Left LAT part: Operator pooling zone
- Central part: Overlength management zone

BASIC KIT CONTAINS

- 1 body block
- 1 left front door double skin (opening at 115°)
- 1 right front door double skin (opening at 115°) (security of doors by 5 points)
- 2 removable side panel simple skin
- 1 fixed back panel simple skin (removable, consult us)
- 1 base 32cm high with 6 removable hatches (2 with mesh opening for ventilation)
- 1 removable roof with 2 openings for ventilation
- 2 pairs of front pillars 31U 19" (2 pairs of rear pillars, please consult us)
- 1 plate of 10 cable entries (with 3 PG21 and 7 PG16)
- 1 plate of 4 cable entries (with 1 PG21 and 3 PG16)
- 6 pre-pointed cable entry plates (making it possible to drill to the desired size)
- 2 removable repositionable parts for docking from 1 to 13 cables (depending on cable size)
- 2 removable and replaceable filters on the inside of the base

MAIN DATA

- Modular block with **double metal plate IP55**, and ring lift in order to ease the handling
- Functional block built with removable elements, delivered with roof and base
- Perfect accessibility in all points of the Modul'O HD
- Reversible front door for right or left open (in standard, lock on the left)
- Lateral panels easily removable from the inside (back panel removable in option)
- IK09 structure completely removable for elements exchange in case of accidental damage
- 3 versions available 31U, 62U and 28U

MANUFACTURING - COMPONENTS

- All the block components, panel, roof, door and the body are made with processed steel
- The base is in stainless steel 304L
- All the parts are coated with high performance paint RAL 7035, in order to prevent all damages due to humidity or salt projection

SPECIFICATIONS

- The handle can be positioned on left door, on request
- Your street cabinet can, on request, be delivered all preequiped according to your needs
- Other colors of the steet cabinet on request

PM Passive single skin in street cabinet - Modul'O HD 2x31U scalable to active	RCAB-48-240000
PM Active doble skin in street cabinet - Modul'O HD 2x31U scalable	RCAB-48-240100



CAPACITY
31, 62 or 93U
according to application



APPLICATION
Perfect for Telecom
and FTTH applications



DIMENSIONS (mm)
H : 1958 x W 2032 x D 750
(Footprint : W 2018 x D 662)
Weight : ≈350 kg (empty)



Patchcord Illustration
supplied with street cabinet

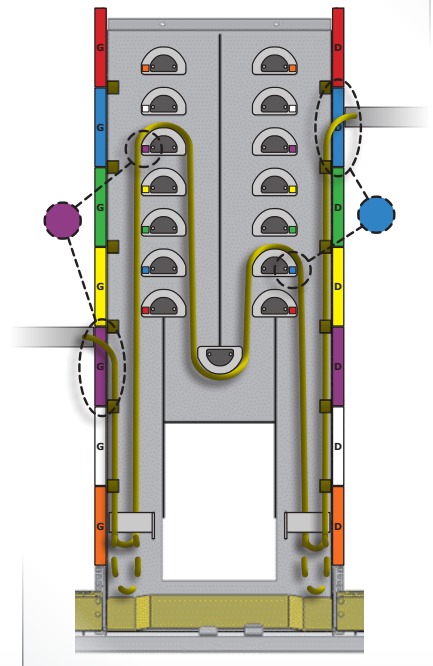



Rotating Splicing Shelf

RANGE TOP

The range of **TOP** regroups all the Rotating Splicing Shelves designed and realized by **TETRADIS**.

- Splicing shelf 4U - 19" (or ETSI on demand) rotating on left (or right), according to the version
- Fixation on amounts 19" (or ETSI), by the front with 2 pairs of adapter shelf brackets 1U 19", or by the back on demand. (accessories sold separately).
- Connectors : multimode or singlemode
- Accepted adapters : SC-APC, SC-UPC, SC-PC, LC dx
- Perfect accessibility to the back zone when opened at 135°.
- Steel design • Color grey RAL 703

TOP 1U equipped with 24 or 36 pigtailed and adapters (R or L)

SPECIFICATIONS

- 1U optical shelf anti-rodent
- Delivered pre-equipped with 12 FO trays, qualified adapters (T) installed and pigtailed numbered, organized, connected to adapters, unshathed and coiled in trays, ready to be spliced
- Capacity : up to 36 ports for SC Simplex connectors

DIMENSIONS

H 43 (1U) x W 440 (without bracket) x D 247.5 (23 mm at the front of the 19" uprights)
Width with brackets in 19" : 486
Empty weight : approx. 4 kg

TOP 1U - 19" - L - equipped 24 adapters and pigtailed Grade B1 9/125...	WACC10-AA-024024
TOP 1U - 19" - R - equipped 24 adapters and pigtailed Grade B1 9/125...	WACD10-AA-024024
TOP 1U - 19" - L - equipped 36 adapters and pigtailed Grade B1 9/125...	WACA10-AA-036036
TOP 1U - 19" - R - equipped 36 adapters and pigtailed Grade B1 9/125...	WACB10-AA-036036

>>> Replace **AA** according to type adapters & pigtailed [**22** = SC-UPC / **24** = SC-APC]
>>> Others configurations, **consult us**

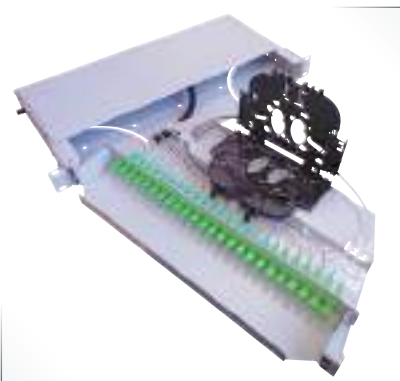

TOP 3U equipped with 4 PLC splitters 1:32 or 2x1:64 (R or L)

SPECIFICATIONS

- 3U optical shelf • Perfect accessibility to the rear area when opened at 135°
- Delivered pre-equipped with 12 FO trays, qualified (T) adapters installed (SC-APC) and PLC splitters (1:32 or 1:64 depending on version)
- Capacity : up to 128 ports for SC Simplex connectors

DIMENSIONS

H 132 (3U) x W 481(19") x D 248 (223 mm at the front of the 19" uprights and 225 mm at the back)
Empty weight : approx. 4.3 kg

TOP 3U - 19" - R - equipped 4 PLC 1:32 preass. SC-APC	WAEB11-24-041032
TOP 3U - 19" - R - equipped 2 PLC 1:64 preass. SC-APC	WAEB11-24-021064

>>> Others configurations, **consult us**



TOP 4U equipped with 144 pigtailed and adapters (R or L)

SPECIFICATIONS

- 4U optical shelf • Perfect accessibility to the rear area when opened at 135°
- Delivered pre-equipped with 12 FO trays identified according to the corresponding column of adapters (from A to L), qualified adapters (T) installed (SC-APC, SC-UPC or LC dx depending on version) and numbered, organized, connected pigtailed to connections, unshathed and coiled in cassettes, ready for splicing (SC-APC 9/125, SC-UPC 9/125, SC-UPC G657 depending on version)
- Capacity : up to 144 ports for SC Simplex connectors

DIMENSIONS

H 176 (4U) x W 481(19") x D 248 (223 mm at the front of the 19" uprights and 225 mm at the back)
Empty weight : approx. 4.6 kg

TOP 4U - 19" - L - equipped 144 adapters and pigtailed Grade B1 9/125...	WACL10-AA-144144
TOP 4U - 19" - R - equipped 144 adapters and pigtailed Grade B1 9/125...	WACM10-AA-144144
TOP 4U - 19" - L - equipped 144 adapters and pigtailed Grade B1 9/125 G657...	WACL11-AA-144144
TOP 4U - 19" - R - equipped 144 adapters and pigtailed Grade B1 9/125 G657...	WACM11-AA-144144

>>> Replace **AA** according to type adapters & pigtailed [**22** = SC-UPC / **24** = SC-APC]
>>> Others configurations, **consult us**





Sliding Splicing Shelf

RANGE TOM

The **TOM** range includes all sliding modular optical shelves designed and manufactured by **TETRADIS**. The core of the shelf (front and adapters, trays coiling/splicing and cable inlet) tilts at 10 °.

MAIN DATA

- Optical shelf 1, 1.5, 2 or 3U - 19" or sliding ETSI with interchangeable front panel
- Mounting on 19" or ETSI posts, from the front or the back, thanks to the adaptive brackets reversible
- Depth adjustable brackets with a pitch of 50 mm ± 15 mm (in 19") and a pitch of 50 mm (in ETSI)
- Fixation also possible on all supports in wall position
- Connectivity: multimode or singlemode • Charcoal black anthracite color - 200 SW 306 F

SPECIFICATIONS

- Wide variety of compatible Singlemode or Multimode connectors
- Comes pre-equipped with trays, adapters and pigtails or PLC or WDM splitters

DIMENSIONS

Height (depending on version): 43.5 (1U) - 83.5 (2U)
 Width 430 (Without square) x Depth 229
 Width with brackets in 19" : 474
 Width with ETSI brackets : 524
 Empty weight : Approximately 3.1 kg (1U), 3.6 kg (2U)

TOM - Splicing/Patching - Singlemode

Optical shelf TOM - 1U 19"/ETSI - eq. SM 9/125 12 adapt. & pigtail. ST	WAAG10-10-012012
Optical shelf TOM - 1U 19"/ETSI - eq. SM 9/125 24 adapt. & pigtail. ST	WAAM10-10-024024
Optical shelf TOM - 1U 19"/ETSI - eq. SM 9/125 12 adapt. & pigtail. SC-APC	WAAH10-24-012012
Optical shelf TOM - 1U 19"/ETSI - eq. SM 9/125 24 adapt. & pigtail. SC-APC	WAAN10-24-024024
Optical shelf TOM - 1U 19"/ETSI - eq. SM 9/125 24 adapt. Dx & 48 pig. SC-APC	WAAO10-24-024048
TOM 2U - 19"/ETSI - equipped 96 adapters and 96 pigtails B1 9/125 SC-APC	WABD10-24-096096

TOM - Splicing/Patching - Mixed Singlemode/Multimode

TOM - 1U 19"/ETSI - 24 SC Dx - equipped 12 adapt. & 24 pigtail. 9/125 SC-UPC + 12 adapt. & 24 pigtail. SC OM3	WAAO23-20-024048
---	-------------------------

TOM - PLC Splitter

TOM - 1U 19"/ETSI - equipped 1 PLC 1:32 preass. SC-APC	WADA10-24-011032
TOM - 1U 19"/ETSI - equipped 4 PLC 2:4 preass. SC-APC	WADA10-24-042004
TOM - 1.5U 19"/ETSI - equipped 2 PLC 1:32 preass. SC-APC	WADB11-24-021032

TOM - WDM Splitter

TOM - 1U 19"/ETSI - equipped 2 DEMUX WDM 1:8 preass. SC-APC	WAEA05-24-021108
---	-------------------------

TOM for coiling

TOM 1U 19"/ETSI for coiling	RTST-52-113000
TOM 3U 19"/ETSI for coiling	RTST-52-113020

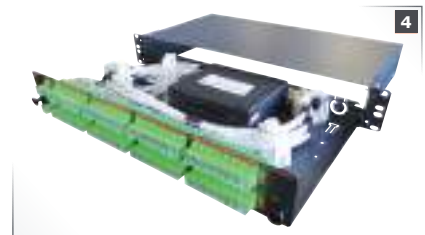

Also available in Hybrid Fiber Optic / Copper RJ45



RESORPTION CAPACITY

TOM 1U for coiling :

- up to 60 m of Ø2 mm patchcords
- up to 30 m of patchcords Ø3 mm

TOM 3U for coiling :

- up to 180 m of Ø2 mm patchcords
- up to 90 m of patchcords Ø3 mm



Secure Optical Box

RANGE COS

The **COS** is perfectly suited for industrial or building applications. These **2 separate compartments** are lockable by 2 different keys making it possible to make the garter part accessible independently of the splicing part.



1



2



3



4



BASIC KIT CONTAINS

- 1 body (to fix on the wall)
- 1 lockable right door (with 1/4 turn or lock depending on version)
- 1 lockable left door (with 1/4 turn or lock depending on version)
- 1 articulable cassette support tray
- 1 hinged connection support plate

MAIN DATA

- Wall fixation
- Can be fixed to each other
- Connectivity: multimode or singlemode
- Optimized for configuration with PLC splitter tray
- Fast installation: TETRADIS offers a complete service to optimize your installation time
- Steel 15 / 10th
- Gray color RAL7035
- IP 10

CAPACITY

- Up to 48 adapters SC simplex (or ST/FC on request)
- Up to 48 pigtailed Single. Grade B1 or Multimode
- 1 PLC splitter tray 1:8, 1:16 or 1:32 (up to 2 trays 1:16)
- 1 to 2 cables in vertical passage
- 1 cable entering from the left of the cabinet from the top or the bottom

DIMENSIONS (mm)

H 170 x W 438 x D 152 (122)
 Width with right door open : 600
 Width with left door open : 722
 Depth with left door open : 410
 Empty weight : approx. 3.9 kg

COS - empty 1

COS - Door plate 48 SCsx adapters - without tray - 1/4 turn	RTST-55-104820
COS - Door plate 48 SCsx adapters - without tray - 2 locks + key	RTST-55-204820

COS - P/P - patching/patching 2

Box COS P/P - equipped XX raccords 9/125 SC-PC	WBAA05-20-0 XX 000
Box COS P/P - equipped XX raccords 9/125 SC-APC	WBAA05-24-0 XX 000
Box COS P/P- S - equipped XX raccords 9/125 SC-APC + Clé	WBAB05-24-0 XX 000
Box COS P/P- S x2 -GSJ - equipped XX raccords 9/125 S LC-PC	WBAB05-80-9 XX 000

COS - S/P - splicing/patching 3

Box COS S/P - equipped XX adapt. & YY pigtailed Grade B1 9/125 SC-APC	WBAA10-24-0 XX 0 YY
Box COS S/P - equipped XX adapt. & YY pigtailed G657 9/125 SC-APC	WBAA11-24-0 XX 0 YY
Box COS S/P- S - eq. XX adapt.& YY pigt. Grade B1 9/125 SC-UPC + Key	WBAB10-22-0 XX 0 YY
Box COS S/P- S - eq. XX adapt.& YY pigt. Grade B1 9/125 SC-APC + Key	WBAB10-24-0 XX 0 YY
Box COS S/P- S - equipped XX adapt. dx & YY pigt. 50/125 OM3 LC + Key	WBAB03-80-0 XX 0 YY

COS - SPL - splicing/splicing 4

Box COS SPL - equipped A tray(s) 12FO for ZZ FO	WBBA10-24-0 ZZ 000
Box COS SPL- S - equipped A tray(s) 12FO for ZZ FO + Key	WBBA10-24-0 ZZ 000

>>> Replace **XX** by the number of desired adapters (06, 12, 16, 24, 32, 40, 44 or 48)
 >>> Replace **YY** by the number of desired pigtailed (06, 12, 16, 24, 32, 40, 44 or 48)
 >>> Replace **A** by the number of desired 12FO trays (1, 2, 3 or 4)
 >>> Replace **ZZ** by the number of desired pigtailed (12, 24, 36 or 48)
 >>> **S** = Secure (delivered with 2 locks mounted + keys)



Optical Box on DIN Rail

RANGE COD

The **COD** is an Optical Box designed to be installed on DIN Rail. It has been optimized to accommodate a high fiber capacity in a small footprint.

MAIN DATA

- Painted steel design in gray RAL7035 color
- Fixing on DIN rail in perpendicular 1 (in parallel or in flat on request)
- Connectivity: multimode or single mode
- Connections accepted: SC-APC, SC-UPC, SC-PC, LC dx
- Screw for fixing the fittings supplied with the fittings in pre-equipped version
- Fast installation: TETRADIS offers a complete service to optimize your installation time
- Perfect accessibility to the interior area of the cabinet once the door is open at 141°
- Box closure by M3 Phillips screw
- Inner bend radius of 25 mm fibers respected

CAPACITY

- Up to 24 input ports for SC Simplex connectivity
- Up to 24 splittings of the type smouv of 45mm
- Up to 2 11mm diameter cables (1 at the bottom and 1 at the top)
- Up to 4 sheaths 5mm in diameter (2 at the top and 2 at the bottom)

SPECIFICATIONS

The COD has also been designed to allow the management of a 72FO cable on 3 consecutive 24FO boxes. The arrival of the cable is at the bottom of the first box, in which are managed the first 2 micro-sheath 12FO corresponding to the first 24 fibers. The other 4 micro-ducts of 12 FO are conveyed through 2 flexible sheaths of diameter 5mm with 2 micro-sheaths by flexible sheath Ø5mm (as illustrated opposite).

DIMENSIONS (mm)

- H 135 x W 56 x D 152 (out of connectors)
- Weight empty : approx. 3.9 kg

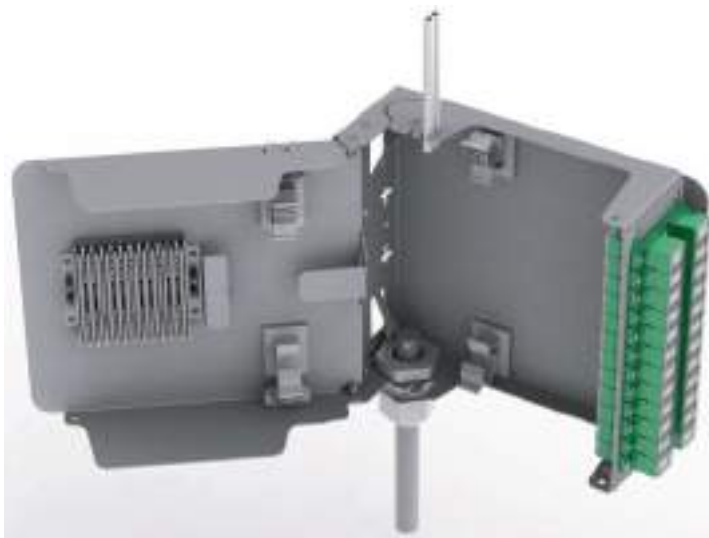

NEW

COD



COD - Front panel 24 SC sx - naked	RTST-56-100010
COD - Front panel 24 SC sx - equipped with 24 adapters SC-APC	WBEN10-24-024000
COD - Front panel 24 SC sx - equipped with 24 adapters SC-UPC	WBEN10-22-024000
COD - Front panel 24 SC sx - equipped with 12 adapters LC-UPC dx + 12 obturators	WBEN10-82-012000
COD - Front panel 24 SC sx - equipped with 24 adapters and 24 pigtails SC-APC	WBEN10-24-024024 1
COD - Front panel 24 SC sx - equipped with 24 adapters and 24 pigtails SC-UPC	WBEN10-22-024024
COD - Front panel 24 SC sx - equipped with 12 adapters dx and 24 pigtails LC-UPC + 12 obturators	WBEN10-82-012024 2

TETRADIS THD FACTORY



T-FanO



ORANGE Solution validated by ORANGE

EDF Solution validated by EDF

Optical Fan-Out

RANGE T-FANO

T-FanOs are universal metal optical fan-out allowing the development of one or more cables to one or more optical shelves. The range consists of 4 models of fan-out, offered equipped in multiple configurations.

COMMON MAIN DATAS

- Fan-out painted steel RAL 7035 textured

T-FanO XS

SPECIFICATIONS

- Equipped with lateral T-slots for securing the cable and sheath using 4 to 10mm PVC rilsans
- Can be fixed on front brackets:
 - in PAS of 31.7mm, 50 and 100mm

DIMENSIONS (mm)

- H 19 x W 130 x D 20
- Weight : 0,049 kg

T-FanO G2 ^{NEW}

SPECIFICATIONS

- 2 snap rivets allow locking
- Bursting parts (combs) and integrated cable grips
- Equipped with lateral openings allowing the fixing of the cables using rilsans PVC or metal of width 4 to 10 mm
- Available in 6 versions

DIMENSIONS (mm)

- H 34 x L 39 x P 83 • Weight : 0,155 kg

T-FanO S

SPECIFICATIONS

- 2 snap rivets allow locking
- Equipped with lateral openings allowing the fixing of the cables using rilsans PVC or metal of width 4 to 10 mm

DIMENSIONS (mm)

- H 46.2 x W 29 x D 132 • Weight : 0.129 kg

T-FanO HD

SPECIFICATIONS

- 2 snap rivets allow locking
- Bursting parts (combs) and parts hooks cables, carrier and grounding in stainless steel 304L
- Equipped, depending on the version, with a piece of cable holder allowing the fixing of the cables using rilsans PVC or metal of width 4 to 10 mm
- Available in 6 versions

DIMENSIONS (mm)

- H 60 x W 90 x D 145 (without cable hangers) or D 180 (with cable grip) • Weight : ≈0,6 Kg

Model	Optical capacity ● Recommended - ○ Compatible											No. of cables accepted						
	12 FO	24 FO	36 FO	48 FO	72 FO	96 FO	144 FO	216 FO	288 FO	432 FO	576 FO	864 FO	1	2	3	4	5	6
T-FanO XS	●	●	●	●	○	○	○						●					
T-FanO S		●	●	●	●	●	○	○					●	●				
T-FanO G2					●	●	●	●	●	○	○		●	●				
T-FanO HD										●	●	●	●	●	●			
T-FanO HD+							○	○	○	●	●	●	●	●	●	●	●	●

Fan-out T-FanO XS 1/24 FO for 1 cable to 1 sheath Ø10mm	RTSC-05-000005	1
Fan-out T-FanO S 24/72FO for 1-2 cables to 6 tubing Ø5mm	RTSC-05-000070	
Fan-out T-FanO G2 144/288FO for 1-2 câbles to 16 tubing Ø5mm	RTSC-05-000012	2
Fan-out T-FanO G2 144/288 FO for 1-2 câbles to 6 tubing Ø10 mm	RTSC-05-000022	
Fan-out T-FanO secondary for 6 tubing Ø10 mm to 12 tubing Ø5 mm	RTSC-05-000030	
Fan-out T-FanO 1x48 FO exit 1 tubing Ø10 mm - thermo sheath + grounding	RTSC-05-000021	3
Fan-out T-FanO HD 432/864 FO - 1-3 cables to 72 sheaths Ø5 mm	RTSC-05-000050	
Fan-out T-FanO HD 432/864 FO - 1-3 cables to 15 sheaths Ø10 mm	RTSC-05-000060	
Fan-out T-FanO HD - 5 cables 48 FO to 6 sheaths Ø10 mm+thermo+grounding	RTSC-05-000061	

Tool Case by TETRADIS

RANGE TOOLING

OPTITOOL+



The complete tool kit ideal for preparing the ends of optical cables.

CONTENTS

- Optical tool case
- 14 mm cutting pliers
- Kabifix FK28 with adjustable swivel blade
- Kevlar scissors
- Miller 103S forceps
- Miller 721 forceps
- Electrician's knife
- FACC WIPPERS Optical Cleaning Paper

TO COMPLETE WITH TOOLBOX

- Set of 9 hexagon keys
- Set of 8 mixed keys
- Set of 6 pipe wrenches
- Set of 7 flat and PMZ screwdrivers
- Adjustable wrench 150 mm
- 250 mm power strip pliers
- hacksaw frame 420 mm
- Measuring tape length 5 m

Tool Case OPTITOOL+ for optical deployment (with OPTITOOL and TOOLBOX)	OTSM-01-000021
Kit OPTITOOL for optical deployment with box	OTSM-01-000022
Kit TOOLBOX - small tools	OTSM-01-000023

*To each need,
a tool case
TETRADIS !*



OPTICLEAN+



All the equipment needed to clean your connectors before splicing.

CONTENTS

- CleanConnect SC/ST
- CleanConnect LC
- Gaz'Net
- Isopronet
- Box of 100 lint-free fabrics
- Box of 100 lint-free sticks
- Fiber Checker -3dBm ferule 2,5mm

Tool Case OPTICLEAN+ with OPTICLEAN kit and Fiber Checker	OTSM-01-000022
---	-----------------------



OPTIBOX



The perfect case to splice your optical trays optimally.

CONTENTS

- 1 rigid PR box
- 1 splicing cassette equipped, according to version

Tool Case OptiBox 9/125 G652 with splice tray - 2000m equipped SC-UPC / SC-UPC	MTSB-30-500222
Tool Case OptiBox 50/125 OM3 with splice tray - 500m equipped	MTSB-30-50008XX
Tool Case OptiBox 50/125 OM1 with splice tray - 300m equipped	MTSB-30-50003XX



TETRADIS THD FACTORY

Singlemode Adapters

RANGE CONNECTIVITY

MAIN DATA

- Sleeve material : ceramic

5	Adapter ST/ST Singlemode	RTSR-10-000100
1	Adapter SC-PC/SC-PC Singlemode blue	RTSR-20-000100
2	Adapter SC-PC/SC-PC Duplex Singlemode blue	RTSR-20-000101
3	Adapter SC-APC/SC-APC Singlemode green	RTSR-24-000100
	Adapter SC-APC/SC-APC Duplex Singlemode green	RTSR-24-000101
4	Adapter FC-PC/FC-PC - DD-Shape	RTSR-30-000100
	Adapter MU-PC Singlemode	RTSR-52-000100
7	Adapter LC-PC/LC-PC Singlemode blue	RTSR-80-000100
8	Adapter LC-PC/LC-PC Duplex Singlemode blue	RTSR-80-000101
9	Adapter LC-PC/LC-PC Quadruplex Singlemode blue	RTSR-80-000102
	Adapter LC-APC/LC-APC Singlemode green	RTSR-84-000100
	Adapter LC-APC/LC-APC Duplex Singlemode green	RTSR-84-000101
	Adapter LC-APC/LC-APC Quadruplex Singlemode green	RTSR-84-000102

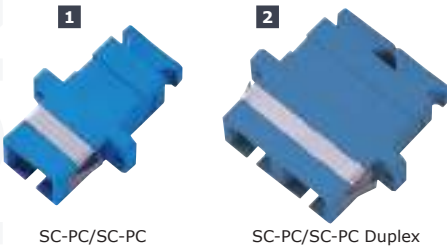

SC-PC/SC-PC

SC-PC/SC-PC Duplex

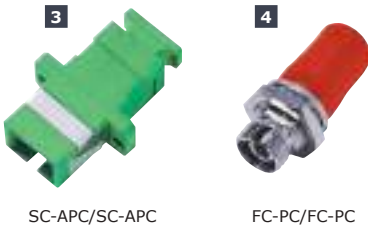

SC-APC/SC-APC

FC-PC/FC-PC



ST/ST

ST/ST
rectangulaire

LC-PC/LC-PC

LC-PC/LC-PC Duplex

LC-PC/LC-PC Quadruplex

Hybrid Singlemode Adapters

RANGE CONNECTIVITY

MAIN DATA

- Sleeve material : ceramic

1	Adapter hybrid ST/SC Singlemode metal body/plastique blue	RTSR-10-000500
2	Adapter hybrid ST/FC Singlemode metal body rectangular	RTSR-10-000501
	Adapter hybrid ST/LC Singlemode metal body rectangular	RTSR-10-000502
3	Adapter hybrid SC/ST Singlemode Duplex	RTSR-10-000520
4	Adapter hybrid FC/SC Singlemode blue rectangular	RTSR-30-000500
5	Adapter hybrid FC-APC/SC-APC Singlemode green rectangular	RTSR-30-000501
	Adapter FC-PC male / FC-APC female	RTSR-30-000600
6	Adapter FC-APC male / FC-PC female	RTSR-34-000600
7	Adapter FC-APC male / FC-APC female	RTSR-34-000650



ST/SC-PC



ST/FC
rectangular

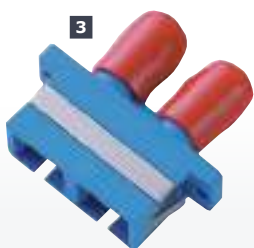

SC-PC/ST Duplex



FC-PC/SC-PC



FC-APC/SC-APC

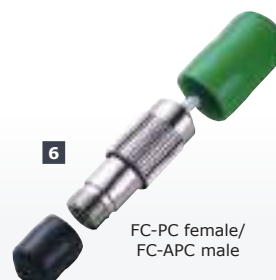

FC-PC female/
FC-APC male

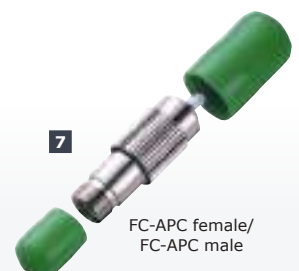

FC-APC female/
FC-APC male

Singlemode Pigtails

RANGE CONNECTIVITY

MAIN DATA

- Sheathed fiber Ø900µ
- Semi-free structure without gel
- LSOH sheath
- Typical insertion loss: ≤ 0.25 dB

REFLECTION RATE

PC	UPC	APC
≥ 40 dB	≥ 50 dB	≥ 60 dB

COMPATIBLE WITH SINGLEMODE CONNECTORS

- **Simplex** : ST, SC, SC-APC, FC, FC-APC, LC, E2000-PC, E2000-APC
- **Duplex** : SC-PC, SC-APC, LC-PC

Examples of Singlemode 9/125 G652 pigtails

Pigtail 9/125/900 Semi-free structure ST - 2 m	RTSJW1-10-00-002X
Pigtail 9/125/900 Semi-free structure SC-UPC - 2 m	RTSJW1-22-00-002X
Pigtail 9/125/900 Semi-free structure SC-APC - 2 m	RTSJW1-24-00-002X
Pigtail 9/125 Semi-free structure FC-PC - 2 m	RTSJW1-30-00-002X
Pigtail 9/125/900 Semi-free structure LC-PC - 2 m	RTSJW1-80-00-002X
Pigtail 9/125 Semi-free structure LC-APC - 2 m	RTSJW1-84-00-002X

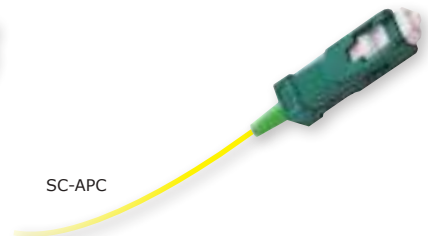
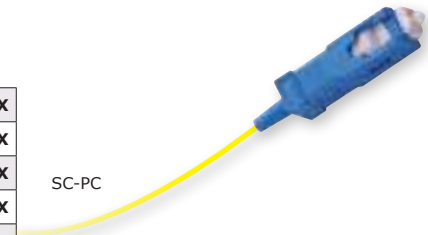
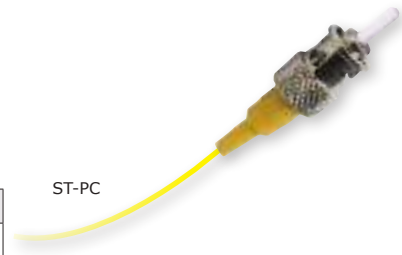

Singlemode Patchcord

RANGE CONNECTIVITY

Optical patchcord are the interface between patch panels and active equipment. They are either **simplex** (1 fiber - 2 connectors) or **duplex** (2 fibers - 4 connectors) depending on usage and can be equipped with different types of connectors. Each patchcord is individually tested to meet the requirements of very high speed networks.

MAIN DATA

- 2 mm or 2.8 mm Simplex LSOH sheath
- Duplex LSOH sheath 2 x 4 mm or 2.8 x 5.6 mm
- LSOH sheath Mini zip 1.8 x 3.6 mm
- Tensile strength = 100 N
- Typical insertion loss: ≤ 0.50 dB

REFLECTION RATE

PC	UPC	APC
≥ 35 dB	≥ 50 dB	≥ 60 dB

COMPATIBLE WITH SINGLEMODE CONNECTORS

- **Simplex** : ST, SC, SC-APC, FC, FC-APC, LC, E2000-PC, E2000-APC
- **Duplex** : SC-PC, SC-APC, LC-PC

Examples of Simplex Singlemode 9/125 patchcord

Patchcord 9/125 Simplex ST/ST - 5 m	RTSJR1-10-10-005J
Patchcord 9/125 Simplex SC-PC/SC-PC - 2 m	RTSJR1-20-20-002J
Patchcord 9/125 Simplex SC-APC/SC-APC - 5 m - (IL< 0.3dB / RL>-55dB)	RTSJR1-24-24-005J
Patchcord 9/125 Simplex FC-PC/FC-PC - 2 m	RTSJR1-30-30-002J
Patchcord 9/125 Simplex EC/EC - 5 m	RTSJR1-78-78-005J
Patchcord 9/125 Simplex LC-PC/LC-PC - 2 m	RTSJR1-80-80-002J

Examples of Duplex-zip Singlemode 9/125 patchcord

Patchcord 9/125 Duplex-zip ST/ST - 2 m	RTSJT1-10-10-002J
Patchcord 9/125 Duplex-zip SC-PC/SC-PC - 5 m	RTSJT1-20-20-005J
Patchcord 9/125 Duplex-zip SC-APC/SC-APC - 2 m	RTSJT1-24-24-002J
Patchcord 9/125 Duplex-zip FC-PC/FC-PC - 5 m	RTSJT1-30-30-005J
Patchcord 9/125 Duplex-zip LC-PC/LC-PC - 2 m	RTSJT1-80-80-002J

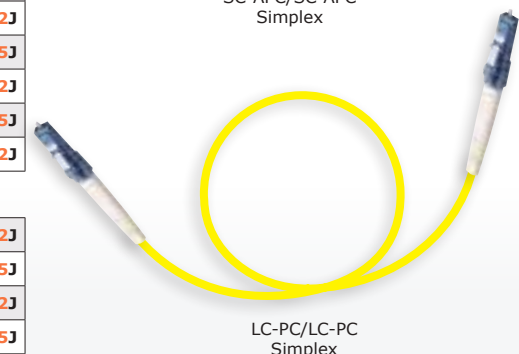
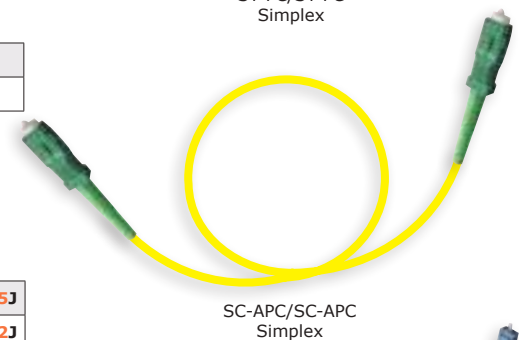
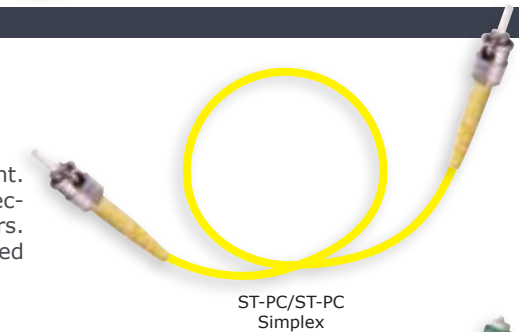

Multimodes Adapters

RANGE CONNECTIVITY

MAIN DATA

• Sleeve material : **bronze**

3	Adapter ST/ST Multimode	RIMR-10-000100
2	Adapter SC/SC Duplex Multimode beige	RIMR-20-000100
1	Adapter SC/SC Simplex Multimode beige	RIMR-20-000101
4	Adapter FC/FC Multimode	RIMR-30-000100
5	Adapter LC/LC Duplex Multimode	RIMR-80-000100
	Adapter LC-PC/LC-PC Quadruplex Multimode	RIMR-80-000102



Hydrib Multimode Adapters

RANGE CONNECTIVITY

MAIN DATA

• Sleeve material : **bronze**

1	Hybrid Adapter ST/SC Simplex Multimode beige	RIMR-10-000500
4	Hybrid Adapter ST/FC Multimode metal body imprint SC Simplex rectangle	RIMR-10-000501
3	Hybrid Adapter SC/ST Duplex Multimode beige	RIMR-20-000500
2	Hybrid Adapter FC/SC Multimode metal/plastic body beige	RIMR-30-000500
5	Hybrid Adapter FC/ST Multimode	Nous consulter



Also available ports obturators



Hydrib Multimode Adapters

RANGE CONNECTIVITY

Adapters fitted with an adapter for the openings of certain FIST enclosures or optical shelves.

7	Adapter ST Singlemode	RTSB-30-000210
6	Adapter ST Multimode	RTSB-30-000211
4	Adapter SC-PC Singlemode	RTSB-30-000220
3	Adapter SC-PC Multimode	RTSB-30-000221
5	Adapter SC-APC	RTSB-30-000224
	Adapter FC-PC	RTSB-30-000230
	Adapter FC-APC	RTSB-30-000234
	Adapter E2000-PC	RTSB-30-000270
	Adapter E2000-APC	RTSB-30-000274
1	Adapter LC-PC Duplex	RTSB-30-000280
2	Adapter LC-APC Duplex Singlemode	RTSB-30-000284



Multimode Pigtails

RANGE CONNECTIVITY

MAIN DATA

- LSOH sheath structure Semi-free 900μ

COMPATIBLE WITH MULTIMODE CONNECTORS

- **Simplex** : ST, SC, FC, LC, MTRJ
- **Duplex** : SC, LC

Examples of Multimode pigtails in 62.5 / 125 OM1

Pigtail 62.5/125 Semi-free structure ST - 2 m	RIMJO1-10-00-002X
Pigtail 62.5/125 Semi-free structure SC - 2 m	RIMJO1-20-00-002X

Examples of Multimode pigtails in 50 / 125 OM2

Pigtail 50/125 Semi-free structure ST - 2 m	RIMJF1-10-00-002X
Pigtail 50/125 Semi-free structure SC - 2 m	RIMJF1-20-00-002X

Examples of Multimode pigtails in 50 / 125 OM3

Pigtail 50/125 OM3 Semi-free structure ST - 2 m	RIMJF1-10-00-002X
Pigtail 50/125 OM3 Semi-free structure SC - 2 m	RIMJF1-20-00-002X



VF45



MTRJ



LC



ST

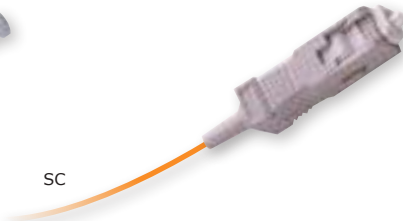

SC

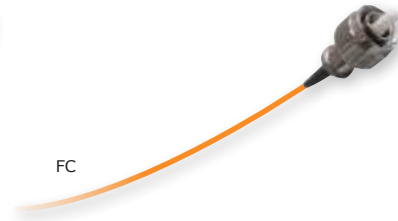

FC

Multimode Patchcords

RANGE CONNECTIVITY

Optical patchcords are the interface between patch panels and active equipment. They are either Simplex (1 fiber - 2 connectors) or Duplex (2 fibers - 4 connectors) depending on usage and can be equipped with different types of connectors. Each patchcord is individually tested to meet the requirements of very high speed networks.

MAIN DATA

- LSOH Simplex 2 and 3 mm sheath
- LSOH Duplex-zip 2 x 4 and 3 x 6 mm sheath
- Tensile strength = 100 N
- Typical insertion loss: ≤ 0.30 dB

COMPATIBLE WITH MULTIMODE CONNECTORS

- **Simplex** : ST, SC, FC, LC, MTRJ
- **Duplex** : SC, LC

Examples of multimodes OM1 patchcords references

Patchcord 62.5/125 Duplex-zip - ST/ST - 5 m	RIMJL1-10-10-005X
Patchcord 62.5/125 Duplex-zip - SC/SC - 2 m	RIMJL1-20-20-002X
Patchcord 62.5/125 Duplex Mini-zip - LC/LC - 5 m	RIMJL1-80-80-005X

Examples of multimodes OM2 patchcords references

Patchcord 50/125 Duplex-zip ST/ST - 2 m	RIMJC1-10-10-002X
Patchcord 50/125 Duplex-zip SC/SC - 5 m	RIMJC1-20-20-005X
Patchcord 50/125 Dx Minizip LC/LC - 2 m	RIMJC1-80-80-002X

Examples of multimodes OM3 patchcords references

Patchcord 50/125 OM3 Duplex-zip ST/ST - 2 m	RIMJC2-10-10-002X
Patchcord 50/125 OM3 Duplex-zip SC/SC - 5 m	RIMJC2-20-20-005X
Patchcord 50/125 OM3 Duplex-zip LC/LC - 2 m	RIMJC2-80-80-002X



FC/FC Duplex



SC/SC Duplex



ST/ST Duplex

PLC Splitters

RANGE CONNECTIVITY

PLC splitters are optical circuits that combine or share services to multiple subscribers.

The optical splitter divides the light of a fiber 2 to 64 or 128 channels depending on the applications.

MAIN DATA

- Flat technology
- High reliability
- Low insertion losses
- Very low PDL (Polarization Sensitivity)
- Very good uniformity
- Drawing and compact dimensions
- Various coupling ratios
- Single mode and multi mode available

APPLICATIONS

- Communication and telecommunications networks
- PON
- LAN, WAN systems
- RAU
- FTTx
- Video
- xWDM

Type	1 : 2	1 : 4	1 : 8	1 : 16	1 : 32	1 : 64
Wave length	1260 - 1650 nm					
Insertion losses (dB) max. (P / S)	4.0 / 3.8	7.3 / 7.0	10.5 / 10.2	14.0 / 13.5	16.9 / 16.5	21.0 / 20.5
Uniformity (dB) max. (P/S)	0.4	0.6	0.8	1.2	1.5	2.5
Return Loss (dB) min. (P/S)	50 / 55					
PDL (dB) max. (P/S)	0.2	0.2	0.3		0.4	
Directivity (dB)	55					
Length of fiber min.	1.2 m (±0.1) (Others lengths on request)					
Fiber types	G657A (Others fibers on request)					
Losses according to λ (dB)	0.3			0.5		
Temperature sensitivity (dB)	0.5					
T°C range	Stockage : -40 à +85°C					

PLC splitter, 1 x 2 - SMF28e/ 900μ - 1260 - 1620 nm - 1 m	RTSC-80-810202
PLC splitter, 1 x 4 - SMF28e/ 900μ - 1260 - 1620 nm - 1 m	RTSC-80-810402
PLC splitter, 1 x 8 - SMF28e/ 900μ - 1260 - 1620 nm - 1 m	RTSC-80-810802
PLC splitter, 1 x 16 - SMF28e/ 900μ - 1260 - 1620 nm - 1 m	RTSC-80-811602
PLC splitter, 1 x 32 - SMF28e/ 900μ - 1260 - 1620 nm - 1 m	RTSC-80-813202
PLC splitter, 1 x 64 - SMF28e/ 900μ - 1260 - 1620 nm - 1 m	RTSC-80-816402

PLC splitter, 2 x 32 - SMF 900μ - 1260 - 1620 nm - 1 m	RTSC-80-823202
PLC splitter, 2 x 64 - SMF 900μ - 1260 - 1620 nm - 1 m	RTSC-80-826402

SMF : Single Mode Fiber

DIMENSIONS (mm)

- 1:2, 1:4 et 1:8 : H 4 x I 4 x W 40
- 1:16 : H 4 x I 4 x W 50
- 1:32 : H 4 x I 7 x W 50
- 1:64 : H 4 x I 12 x W 60

Also available in 250μm and 2 or 3 mm on request ... Consult us!

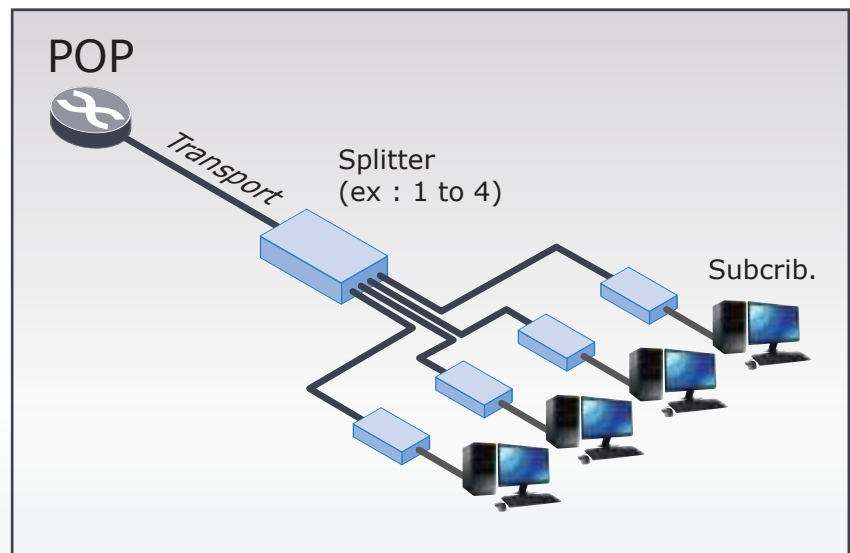

Break-Out Preconnect cable

RANGE CONNECTIVITY

The break-out is a cable which may contain 2 to 24 fibers each fiber is wrapped with a 2mm sheath. The sheath is UV proof and allow an outdoor use. It's compliant with the LSZH characteristics and answers to the environmental requirements.

MAIN DATA

- UV stabilized sheath for outdoor use
- LSZH characteristics meeting environmental requirements
- Compliance IEC 332-1 and IEC 332-3C
- Exist in Multimode and Singlemode
- All connectors
- 900µ Polyamide coating, white, 850 ± 50 µm outer diameter
- Protection of unitary FOs Aramid Wicks
- Sheath of each fiber Ø2 mm type LSZH
- Color variable according to fiber type (Singlemode / Multimode)

- Each fiber is numbered on its surface
- With central carrier (100% dielectric) according to the FO capabilities of the Break-out cable
- Type LSZH outer sheath with FO type marking every 1 meter

APPLICATIONS

- RAU optique / Backbone LAN
- PMV / Weather station

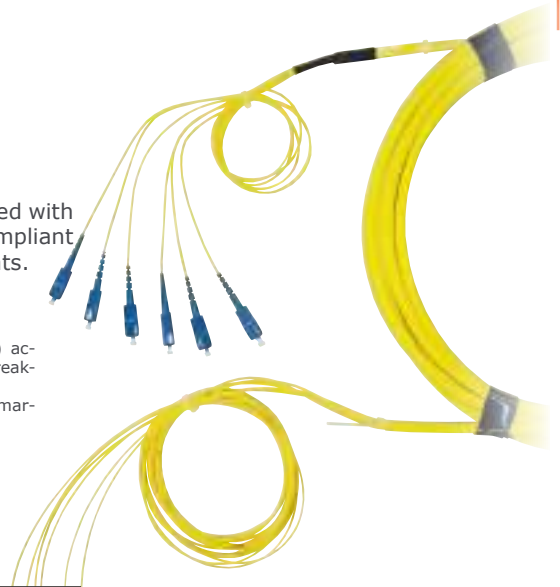

Technical Specifications			
Maximum voltage (at the installation)	4 FO : 500 N 6 FO : 800 N 8 FO : 1000 N 12 FO : 2000 N 24 FO : 4000 N	Reversible Fiber stretching 0.3%	IEC norm 60794-1-2-E1
Crushing	500 N / 10 cm	Reversible	IEC norm 60794-1-2-E3
Impact	10 J	Reversible No degradation	IEC norm 60794-1-2-E4
Dynamic curvature radius	Ø 20 max per cable 20 cycles maximum	No degradation	IEC norm 60794-1-2-E6
Radius of static curvature	Ø 20 max per cable	No degradation	IEC norm 60794-1-2-E10
Temperature cycling	From -20°C to +60°C 2 Cycles maximum	0.1 dB to 1550 nm Reversible	IEC norm 60794-1-2-F1

Temperature range	
T° of storage	from -20°C to +60°C
T° in operating	from -20°C to +60°C
T° in installation	from 0°C to +50°C

Properties in case of fire	
Propagation	CEI Norm 20-22/3-4
Smoke density	CEI Norm 20-37/5
Corrosive gaz emission	CEI Norm 20-37/3 CEI Norm 20-37/7

Coding Break-Out Cables

Given the multitude of connectors, fiber types, and lengths, we can not list all Break-Out cables in a table. Also, to meet your specific expectations, we provide you with an excerpt from our internal codification.

Singlemode Cable

CTSPAY-GBBGCC-DDDZ

BB & CC	Connectors Type			
	PC	UPC	APC	APC ajusté
ST	10	12		
SC	20	22	24	25
FC	30	32	34	35
MTRJ	60			
E2000	70		74	
EC			78	
VFO	79			
LC	80		84	
VF-45	90			

DDD	Lenght (in m)

Multimode Cable

CIMPAY-GEEGFF-DDDZ

EE & FF	Connectors Type	
	PC	
ST	10	
SC	20	
FC	30	
MTRJ	60	
E2000	70	
VFO	79	
LC	80	
VF-45	90	

Z	Pose Mode
0	Without sock
1	With sock

A	Cable type		
FO number	Free	900µ	Break Out
4	A	I	R
6	B	J	S
8	C	K	T
12	D	L	U
24	E	M	V
36	F	N	W
48	G	O	X

Y	Fiber type
1	9/125 - G652
3	50/125 - standard
6	62.5/125

G	2.8 mm braiding
0	Without braiding
1	With braiding
9	On request

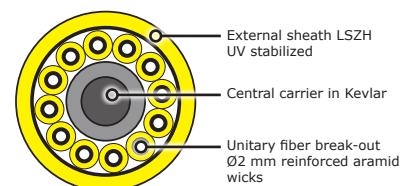

FO Nb	Ø FO	Ø Break-Out	Weight
4	0.9 mm	6.8 mm	45 kg/km
6	0.9 mm	8.4 mm	79 kg/km
8	0.9 mm	9.5 mm	90 kg/km
12	0.9 mm	12.6 mm	165 kg/km
24	0.9 mm	15.0 mm	210 kg/km

Singlemode Cable

Break Out Cable 6 FO - 9/125 - 6 x SC-PC / 6 x SC-PC - 10 m	CTSPS1-020020-0100
Break Out Cable 6 FO - 9/125 - 6 x SC-APC / 6 x SC-APC - 10 m	CTSPS1-024024-0100
Break Out Cable 12 FO - 9/125 - 12 x SC-PC / 12 x SC-PC - 10 m	CTSPU1-020020-0100
Break Out Cable 12 FO - 9/125 - 12 x SC-APC / 12 x SC-APC - 10 m	CTSPU1-024024-0100
Break Out Cable 24 FO - 9/125 - 24 x SC-PC / 24 x SC-PC - 10 m	CTSPV1-020020-0100
Break Out Cable 24 FO - 9/125 - 24 x SC-APC / 24 x SC-APC - 10 m	CTSPV1-024024-0100

Multimode Cable

Break Out Cable 12 FO - 50/125 - 12 x SC / 12 x SC - 10 m	CIMPV3-020020-0100
Break Out Cable 24 FO - 50/125 - 24 x SC / 24 x SC - 10 m	CIMPV3-020020-0100



SERVICES BY TETRADIS

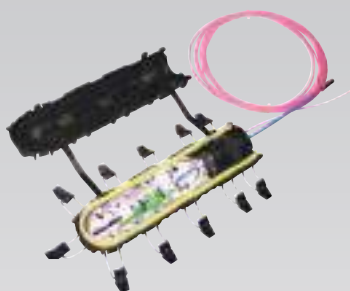

OFDR with connectors equipped with 6 fusion splices and 2 adapters SC-APC Sx

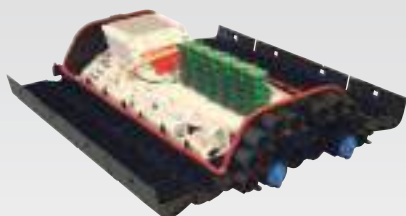

BPE-O Size 3 equipped with 36 adapters SC-APC Dx

Several references... 1 product !

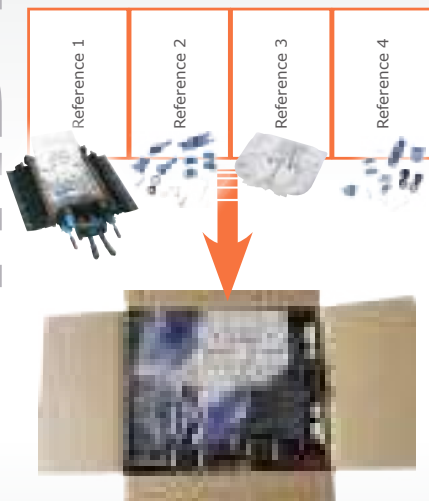

TETRADIS PARTNERS

In order to offer you a product offer that is as complete as possible, **TETRADIS** partners with renowned partners such as **COMMSCOPE** or **3M**.

Thanks to these **TETRADIS** service provider offers, you are offered integrated products according to your needs or made on demand. **Save time on your deployments !**

INTEGRATION SERVICE

Through the end customers, **TETRADIS** offers all its customers an **Integration Service**. The servers, street cabinets, optical shelves and other passive components are thus integrated, as needed, upstream of the field deployment.

Save time on the field and quality assurance !

To better identify you ...

Thanks to this pictogram, easily identify the proposed references in **TETRADIS Integration**



KITTING SERVICE

We offer all our customers, a kitting service, to group all the desired products under a single reference.

Why choose our Kitting Service?

- **Simplified logistics management:** receiving all components at the same time
- **Site management facilitated:** facilitates dispatch to different sites
- **Better financial management:** products are ordered according to need, reduction of lost parts
- **Administrative management:** optimizing inventory management

To better identify you ...

Thanks to this pictogram, easily identify the proposed references in **TETRADIS Kitting**



GR3 Indoor Cabinet

RANGE OPTICAL CABINET

The FIST-GR3 is a multi-purpose cabinet, easy to install, developed to receive fiber management equipment.

In PM configuration, 3 functional blocks are distinguished.

- Right LAT Part: Subscriber AR Area
- Left LAT part: Operator pooling zone
- Central part: Overlength management zone

MAIN DATA

- Bay painted in light gray (RAL 7035)
- The width depends on the configuration
- Mounting against a wall, single or adjacent (optional kit)
- Back-to-back mounting
- Standard 19" distributor
- Height 2200 mm in 2 zones 42U
- Bay divided into 3 zones (Operators, Management, Subscribers)
- Single garter length
- Unique front-end management
- Devices for securing cables and integrated tubes in lateral parts
- Option to add optional: LAT / AR panels / AV doors

CAPACITIES

Up to 14 shelves FIST 3U.
Height unit 19" = 2 zones of 42U

DIMENSIONS (mm)

Together : H 2200 x W (900 x 2) x P 300
Central body : H 2200 x W 600 x D 300
Floor area < 0.54 m²

APPLICATION

PM or NRO shelter dispatcher.

PM 1584 FO 19" AV for shelter - GR3 2x42U with central coiling	RCAB-34-000080
Angle coupling kit for GR3	RCAB-34-000003
GR3 cabinet equipped with 8 shelves GPS3 3U patching / patching	RCAK-33-000010



TETRADIS realizes the integration of your cabinet according to your needs!

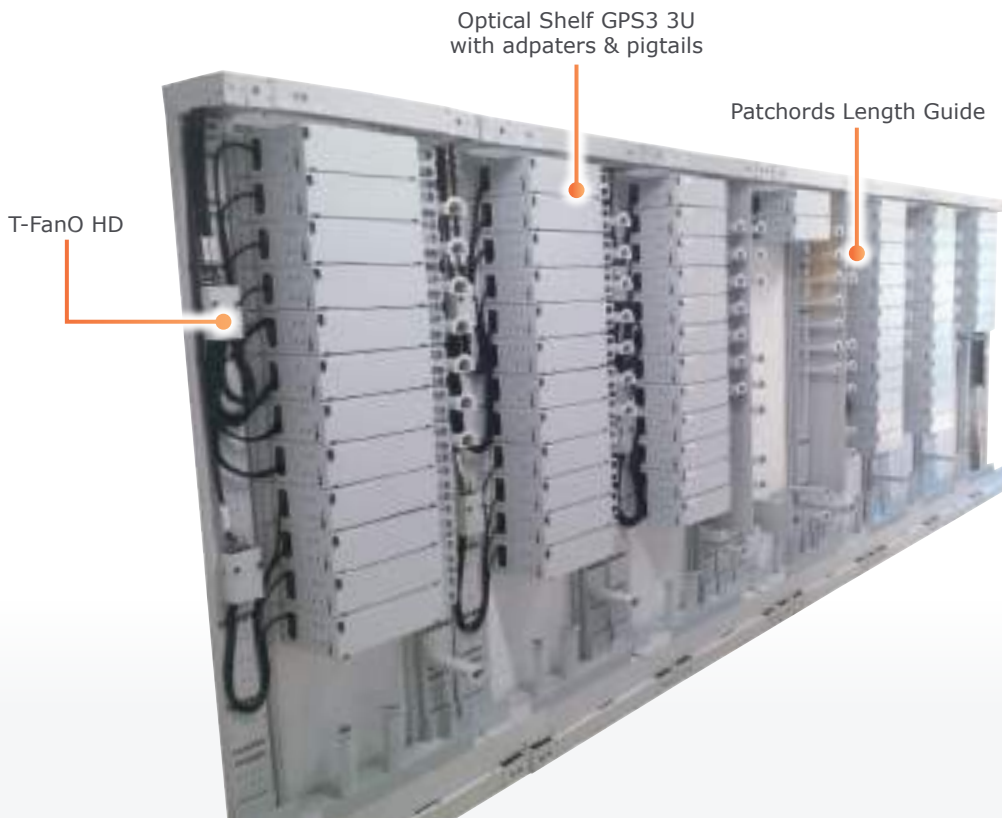

FIST GCO2

RANGE FIBER CLOSURE

Designation	Max splices	Max trays	Seal Type	No. of entries/exits	Max cable	Max coiling	Volume
FIST GCO2 FR6	288	24 FIST SLE 12 sp.	Gel or thermo block	1 passage and up to 24 cables max ⁽²⁾	720 FO mod.12	102 m	9.9 L
FIST GCO2 FR6 HD	336	28 FIST SLE 12 sp.	Gel or thermo block	1 passage and up to 24 cables max ⁽²⁾	720 FO mod.12	102 m	9.9 L
FIST GCO2 BCx	672	56 SLE 12 sp.	Gel or thermo block	According to the E/E configuration, refer to the descriptive pages	720 FO mod.12	126 m	15.65 L
FIST GCO2 BDx	960	80 SLE 12 sp.	Gel or thermo block	According to the E/E configuration, refer to the descriptive pages	720 FO mod.12	162 m	19.05 L
FIST GCO2 BEx	1344	112 SLE 12 sp.	Gel or thermo block	According to the E/E configuration, refer to the descriptive pages	720 FO mod.12	210 m	22.30 L

⁽¹⁾ 12 drops possible par superposition ou encore combinaison
⁽²⁾ le nombre dépend du diamètre et si E/S GEL

Compatible output types according to FIST GCO2 model :

FIST GCO2 Bx6

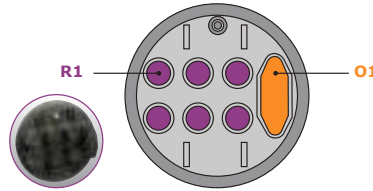

Base Ø 247 mm for **FIST GCO2 Bx6** containing:
 - 6 round outputs (R1) Ø 30 mm
 - 1 oval exit (O1) Ø 30 x 82 mm

FIST GCO2 Bx8

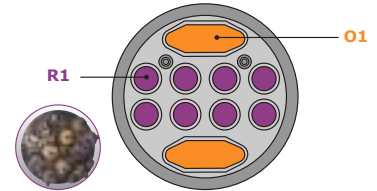

Base Ø 247 mm for **FIST GCO2 Bx8** containing:
 - 8 round outlets (R1) Ø 30 mm
 - 2 oval outputs (O1) Ø 30 x 82 mm

FIST GCO2 Bx16

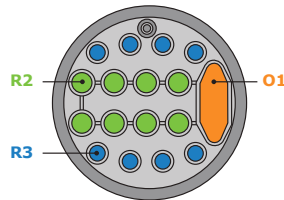

Base Ø 247 mm for **FIST GCO2 Bx16** containing:
 - 8 round outputs (R2) Ø 20 mm
 - 8 round outputs (R3) Ø 13.5 mm
 - 1 oval exit (O1) Ø 30 x 82 mm

FIST GCO2 FR6

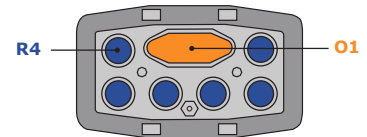

Base plate H 150 x 254 mm for **FIST GCO2 Fx6** containing:
 - 6 round outputs (R4) Ø 30 mm
 - 1 oval exit (O1) Ø 30 x 82 mm



FIST GCO2

RANGE FIBER CLOSURE

COMMSCOPE®



FIST GCO2 Bx6



FIST GCO2 Bx8



FIST GCO2 Bx16

Watertight Fiber Closure Fist GCO2 BC6 + Earth + Valve	RTSB-10-000020
Watertight Fiber Closure Fist GCO2 BD6 + Earth + Valve	RTSB-10-000030
Watertight Fiber Closure Fist GCO2 BE6 + Earth + Valve	RTSB-10-000040
Watertight Fiber Closure Fist GCO2 BC8 + Earth + Valve	RTSB-10-000022
Watertight Fiber Closure Fist GCO2 BD8 + Earth + Valve	RTSB-10-000032
Watertight Fiber Closure Fist GCO2 BE8 + Earth + Valve	RTSB-10-000042
Watertight Fiber Closure Fist GCO2 BC16 + Earth + Valve	RTSB-10-000021
Watertight Fiber Closure Fist GCO2 BD16 + Earth + Valve	RTSB-10-000031
Watertight Fiber Closure Fist GCO2 BE16 + Earth + Valve	RTSB-10-000041
FLAT FIST GCO2 - FR6 shortened dome (max 288 splices)	RTSB-12-000030
FLAT FIST GCO2 - FR6 HD NV	RTSB-12-000040



FIST GCO2 FR6

Accessories

All accessories for FIST GCO2 can be integrated in our kitting, ask us for advice!

Set of 4 trays Slim SOSA2 4SLE 12 adapters 'smouv' - 2 UMS	RTSB-30-000050	
Set of 4 trays Slim SOSA2 8SLE 12 adapters 'smouv' - 4 UMS	RTSB-30-000052	1
Set of 4 trays SOSA2 4SC 4 adapters 'smouv' - 2 UMS	RTSB-30-000050	
Set of 4 trays SOSA2 8SC 4 adapters 'smouv' - 4 UMS	RTSB-30-000052	2
Tray cover SOSA2 (x 20)	RTSB-40-000575	
Set of 2 trays SOSA2 2SE 12 adapters 'smouv' - 2 UMS	RTSB-30-000010	
Set of 4 trays SOSA2 4SE 12 adapters 'smouv' - 4 UMS	RTSB-30-000020	
Set of 5 trays SOSA2 5SE 12 adapters 'red smouv' - 4 UMS	RTSB-30-000025	3
Tray cover SOSA2 (x 20)	RTSB-40-000575	
Oval Outlet - Compatible O1 for micro-sheath cable (OSK-CC)	RTSB-30-000104	
Oval Outlet - Compatible O1 pour câble à tube (OSK-LTS)	RTSB-30-000102	
Ronde Exit - Compatible R1/R4 for micro-sheath cable (RSK-CC)	RTSB-30-000103	
Ronde Exit - Compatible R2/R3 for micro-sheath cable (RSK-16-CC)	RTSB-30-000106	
Ronde Exit - Compatible R1 for tube cable (RSK-LTS)	RTSB-30-000101	
Ronde Exit - Compatible R4 for tube cable (FX-RSK-LTS)	RTSB-30-000121	
Ronde Exit - Compatible R2/R3 for tube cable (RSK-16-LTS)	RTSB-30-000105	
Thermo oval outlet. split (CSEAL-2NW) Compatible O1	RTSB-30-000112	
Thermo oval outlet. split (CSEAL-1NW) Compatible R1/R2/R3/R4	RTSB-30-000111	



COMMSCOPE®



TENIO

GAMME FIBER CLOSURE

TENIO fiber closure consist of modular elements that combine a high-performance fiber management system with a new, intuitive sealing system, reducing references and improving installation time.

The modularity of TENIO allows for flexibility and scalability in the network architecture while reducing initial costs but also reducing inventory.

BASIC KIT CONTAINS

- 1 dome with peripheral seal
- 1 base with fiber management system and splicing
- 2 half-blocks of side gels
- 1 braided sheath
- 1 rubber tube

CAPACITIES

- Up to 144 splices in Size 1 and up to 288 splices in Size 2
- Up to 12 trays of 12 fibers in Size 1 and up to 24 trays of 12 fibers in Size 2 (available as an accessory)
- Up to 6 Input / Output blocks gel (available as an accessory)

MAIN DATA

- IP 68
- Mechanical maintenance of cables
- Interchangeable gel inlets / outlets
- Dedicated standard: NF / EN 50411-2-10 FTTH G
- Hat standard: IEC-EN 61753-1
- Standard Test Procedure: NF / EN 61300-X-Y
- Environment category: G

DIMENSIONS (mm)

TENIO T1 : H 345 x W 230 x D 134 - Volume : 5.95 L
 TENIO T2 : H 405 x W 230 x D 134 - Volume : 9.9 L

TENIO T1 maxi 144FO - 6 trays 12FO - 4 Obturators - Fixing kit	RTSB-15-000015	1
Kit TENIO T1 + 12 trays + 1x2b + 1x3a + 5xCTU-L + Fixing	KDA-AL00-C1D100Y2	
Tray 12 fusions NextGen for TENIO T1	RTSB-15-000050	
TENIO T2 maxi 192FO - 4 K7 24FO - 4 Obturators - Fixing kit	RTSB-15-000025	2
Kit TENIO T2 12 trays- 1 E/S 2a + 1 E/S 3a + 4 Obt. + 5 CTU-L + Fixing	KDC-CL00-A1D104Y2	
Tray 24 fusions NextGen for TENIO T2	RTSB-15-000052	

>>> Kits can be made according to your needs: ask us for advice!

Accessories

All accessories for TENIO can be integrated in our kittings, ask us for advice!

TENIO Gel Block - Obturator	RTSB-15-000100
TENIO Gel Block 2 E/S 13-16mm - 2a	RTSB-15-000121
TENIO Gel Block 2 E/S 11-14mm - 2b	RTSB-15-000122
TENIO Gel Block 2 E/S 9-12mm - 2c	RTSB-15-000123
TENIO Gel Block 3 E/S 7-10mm - 3a	RTSB-15-000131
TENIO Gel Block 3 E/S 5-8mm - 3b	RTSB-15-000132
TENIO Gel Block 4 E/S 3-6mm - 4	RTSB-15-000141
TENIO Gel Block 5 E/S 2-4mm - 5	RTSB-15-000151
TENIO Fix Cable - CTU Small - without carrier fixing for gel blocks 4 and 5	RTSB-15-000105
TENIO Fix Cable - CTU Large - avec carrier fixing for gel blocks 2 and 3	RTSB-15-000106

Mini-OTE 2 (connectorized PBO)

GAMME FIBER CLOSURE



The PBO is the nerve center of the subscriber connection.

At the same time at the closest of the customer but also far from the centers where only specialists intervene, it is often solicited, by multiple interventions of less experienced technicians.

With this in mind, **COMMSCOPE**, has chosen to promote this new range combining flexibility and robustness by integrating a consolidation point in waterproof connections closer to the subscriber.

MAIN DATA

- Innovative deployment solution, and compact 2 liters approximately
- Adapted to the underground
- Adapted to the air
- Waterproof IP 68
- 2-4-6-8 SC-APC SEALED connectors
- Passage topology (5-15 mm)
- Stitching topology (2x 5-10 mm)
- Network Test Point
- Once the product is installed and closed: perennial waterproofness and reliability

CAPACITIES

- Up to 24 splices
- Up to 2 trays 12 splices

DIMENSIONS (mm)

H 358.5 x L 166 x P 129.3
Volume : 7.70 L

	Mini OTE2 IP68 black + Mobra wall equipped 1 splitter PLC 1:4	RTSB-72-001010A
	Mini OTE2 IP68 black + Mobra wall equipped 1 splitter PLC 1:8	RTSB-72-001011A

COMMSCOPE®



White Version, 4 ports



Black Version, 8 ports



DROP Cable

RANGE CONNECTIVITY

The DROP Cable was designed by **COMMSCOPE** to be robust in an environment under heavy stress. The connectors have been specially reinforced to withstand extreme temperatures, humidity, UV, exposure to chemicals and other harsh conditions.

The use of DROP cables with the Mini OTE 2 simplifies the use of splices. The Plug & Play solution provides a reliable and durable connection for all network deployments.



Drop Cable DLX 1FO - SC-APC

MAIN DATA

- Intuitive and easy connection of Drop Cables on terminals
- Designed for use in all environmental categories: Air (Class A), Underground (Class G and Category S) as defined in IEC 61753-1
- Compatibility with standard connectors
- Easy maintenance without splice breakage by plugging in the Drop Cable.
- Built to IEC 61755 optical interface standards
- Compatible with SC-APC connectors

	Drop 1FO DLX IP68 - SC-APC	RTSB-72-006xxxA
--	----------------------------	------------------------

Replace **xxx** by the desired length : 30, 50, 100 ou 150 m

>>> Available also preconnectorized to a PTO

	Drop 1FO DLX IP68 - SC-APC + PTO 2FO 1 adapter SC-APC	RTSB-72-006xxxB
	Drop round G657B3 1FO DLX IP68 - SC-APC + PTO 2FO 1 adapter SC-APC	RTSB-72-104xxxA

Replace **xxx** by the desired length : 30, 50, 100, 150, 200 ou 250 m

COMMSCOPE®



COMMSCOPE®

BUDI range

RANGE FIBER CLOSURE

BUDI is a range of compact enclosures for FO splice protection, intended for indoor or outdoor use. The enclosures are specifically designed for fast deployment and easy connection to the customer.

Available with splices and/or patches, high density connectors, small and large footprints. They offer flexible solutions for a wide range of applications.

MAIN DATA

- BUDI wall housings are designed to operate in category C (controlled), category G (outdoor floor level) and category A (airborne) as characterized by IEC 61753-1.
- The materials are LSZH; fireproof.
- UV resistant materials for above ground use outdoors
- Multiple cable ports available and wraparound cable sealing blocks
- Possible integration of passive components
- Removable housing cover
- Capacities from 6 to 36 SC simplex connectors, depending on version.
- Compatible with Mini Breakout cable
- For FIST splice protections minimum of 16 UMS units for splice version and 8 UMS for splicing/patching. This UMS version is compatible with SOSA splice trays.
- A cable loop can be stored for mid-way access
- With or without lock
- Several accessories available for different types of cables
- Integration compatible with FSASA splitter
- Available in patching/patching or splicing/patching

CAPACITIES

	Max adapters SC sx	Max adapters LC dx	SOSA2-SC	SOSA2-4 SE	SOSA2-5 SE	SLE
BUDI-2S	6	12	1 tray 12 FO			
BUDI-1S	x	x	80	120	144	240
BUDI-1S-T	16	32	48	72	84	144
BUDI-S-SP	x	x	128	192	240	284
BUDI-S-TB	24	48	2 trays 24 FO + 1 tray 8 FO + 1 tray 6FO			
BUDI-S-TN	24	48	64	96	120	192
BUDI-M-SP	x	x	160	240	300	480
BUDI-M-TB	36	72	4 trays 24 FO + 1 tray 8 FO + 1 tray 6FO			
BUDI-M-TN	36	72	4 blocks SOSA2 48 connectors			

BUDI-2S-S	RTSB-49-001010
BUDI-2S-T equipped with 6 adapters duplex + 12 pigtails LC-APC 9/125	RTSK-72-0840612
BUDI-2S equipped with 4 adapters SC-APC sx + PLC 1 to 8	RTSK-91-013060
BUDI-2S equipped with 2 adapters SC-APC sx + PLC 1 to 4	RTSK-91-013061
BUDI-1S-SP with key	RTSB-50-001020
BUDI-1S-T-B with key	RTSB-50-002020
BUDI 1S T adapters 48 adapters & pigtails SC-APC + E cable + pigtails support	RTSK-73-124486
BUDI-S-SP-B with key	RTSB-51-001020
BUDI S SP B adapters 12 R&P ST 9/125 + 12 R&P ST 62,5/125	RTSK-74-110246
BUDI-S-T	RTSB-51-002020
BUDI-M-SP with key	RTSB-53-001020
BUDI-M-TN-B with key	RTSB-53-002020



BUDI 2S

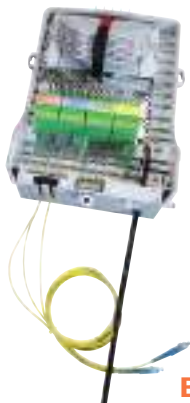

BUDI 1S



BUDI S



BUDI M

Optical Terminal Outlet PTO²

GAMME OPTICAL BOX

The particularity of the PTO2 plug is its simplicity of implementation thanks to the separation of the fixing zone and the zone of coiling and splicing.
The base is dedicated to the functions of fixing, routing and anchoring the cable, while the cassette carries all the optical equipment.

With a **capacity of 1 to 4 FO**, it can be fixed with a double-sided adhesive, be screwed to the wall, on mounting box or clipped on DIN rail.

MAIN DATA

- Connections SC Simplex or LC Duplex
- G657A2 fiber, length 80 cm, IL <0.3dB; RL> 55dB
- Color: white RAL9010
- Wall mounting, by double-sided adhesive, on built-in boxes or DIN rail
- Multiple cable entries:
 - 2 lateral for fixing against baseboards
 - 2 at the top for fixing along the wall
 - 1 on the back for use on a recessed box
 - 1 at the bottom for outer cables with larger diameters
- Zone of coiling and splicing
- UV1 compliant

DIMENSIONS (mm)

Wall fixing : H 80 x W 83 x D 28

	Subscriber box PTO ₂ 1FO equipped with 1 adapter & pigtail SC-APC G657A2	RTSB-73-813111000
	Subscriber box PTO ₂ 2FO equipped with 2 adapters & pigtails SC-APC G657A2	RTSB-73-823122000
	Subscriber box PTO ₂ 4FO equipped with 4 adapters & pigtails SC-APC G657A2	RTSB-73-843144000

>>> Also available in pre-wired kit

MAIN DATA

- White cable, sheath LSZH
- Cable diameter: 4.2 mm
- Length 20, 30 or 50m
- Packaged in a cardboard reel with optimized coefficient of friction

	Kit pre-wired PTO ₂ 1FO equipped with 1 adapter SC-APC G657A2 -	RTSB-73-8131160xx
	Kit pre-wired PTO ₂ 2FO equipped with 2 adapters SC-APC G657A2 - 20m	RTSB-73-8231270xx
	Kit pre-wired PTO ₂ 4FO equipped with 4 adapters SC-APC G657A2	RTSB-73-8431480xx

Replac **xx** by the desired length : 20, 30 ou 50 m



Optical termination box

GAMME OPTICAL BOX

This optical transition box is a sleeve specifically designed for the deployment or maintenance of the FTTH end line.

MAIN DATA

- Material: PC
- Black color
- Waterproof: IP 68
- Mechanical resistance: IK 08
- Path for G657 fibers

DIMENSIONS (mm)

- W 160 x H 89 x D 28
- Volume < 0,4 liter

Optical termination box IP68

RTSB-70-002050

PARTICULARITIES

- Ultra compact case <0.4 liter
- 2 cable entries drop up to Ø 6-7 mm
- Up to 4 splicers





Compatibility of BPE-O inputs

RANGE FIBER CLOSURE

C : compatible S4-12
E : compatible S5-18
N : nécessite D6-18

		1		2			3		4		5		6		
		BPEO T0		BPEO T1			BPEO T1.5		BPEO T2		BPEO T3				
S S S S	ECAM Simple	S3-7	●	●	●	●	●	●	●	●	●	●	●	●	4 5
		S3.5-9.5	●	●	●	●	●	●	●	●	●	●	●	●	
		S4-12	●	●	●	●	●	●	●	●	●	●	●	●	
		S5-18	●	●	●	●	●	●	●	●	●	●	●	●	
D D D D D D	Body for ECAM Double	D6-18	●	●	●	●	●	●	●	●	●	●	●	●	2 3 6 1
	ECAM Double	D6-9	●(1)	●	●	●	●(1)	●(1)	●(1)	●(1)	●	●	●	●	
		D9-12	●(1)	●	●	●	●(1)	●(1)	●(1)	●(1)	●	●	●	●	
		D12-15	●(1)	●	●	●	●(1)	●(1)	●(1)	●(1)	●	●	●	●	
		D15-18	●(1)	●	●	●	●(1)	●(1)	●(1)	●(1)	●	●	●	●	
		D5-20	●	●	●	●	●	●	●	●	●	●	●	●	
C E C C	ECAM Extended	D12 - 12x1.5mm	●	●	●	●	●	●	●	●	●	●	●	●	
		D18 - 7x5.5mm	●	●	●	●	●	●	●	●	●	●	●	●	
		D12 - 10x2mm	●	●	●	●	●	●	●	●	●	●	●	●	
		D12 - 4x4mm	●	●	●	●	●	●	●	●	●	●	●	●	
	Integrated wall bracket	NC	●	●	●	●	●	●	●	●	●	●	●	●	
	Kit wall fix. and pole V2 for T1	NC	●	●	●	●	●	●	●	●	●	●	●	●	
	Kit wall fix. V2 for T2 and T3	NC	●	●	●	●	●	●	●	●	●	●	●	●	
	Optical capacity	48 FO	144 FO			144 FO		336 FO		576 FO					
	Volume in liter	< 2 L	4.8 L			5.6 L		17.3 L		23.8 L					
	Allowable cable diameters	3 to 18 mm	3 to 20 mm			3.5 to 18 mm		4 to 27 mm		4 to 27 mm					
	Lenght x Width x Depth (mm)	240 x 230 x 90	340 x 205 x 92			240 x 230 x 90		520 x 341 x 149		661 x 341 x 149					
	Nb of PAS	4	12			12		28		48					
		BPEO T0	BPEO T1			BPEO T1.5		BPEO T2		BPEO T3					

(1) Requires a body for ECAM Double D6-18

BPE-O T0



- BPEO T0** (2 possible configurations)
- 1 dual port for **ECAM Double Body**
 - 2 single ports for ECAM Ø3.5-9.5 (S9.5)
 - 12 single ports for ECAM Ø3-7 (S7)
- Or
- 2 single ports for ECAM Ø4-12 (S12)
 - 2 single ports for ECAM Ø3.5-9.5 (S9.5)
 - 12 single ports for ECAM Ø3-7 (S7)

BPE/O EVOL T0 4 pas 12 S3-7+2 S3.5-9.5+1 D6-18 **RTSB-01-200000**

BPE-O Taille 1

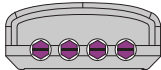

- Straight Seal EOC**
- 4 single ports for ECAM Ø5-18 (S18)

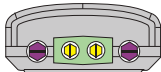

- Primary Diversion CDP** (2 possible config.)
- 1 Double port for ECAM PAS Ø5-20 (D20)
 - 2 single ports for ECAM Ø5-18 (S18)
- Or
- 2 single ports for ECAM Ø4-12 (S12)
 - 2 single ports for ECAM Ø5-18 (S18)

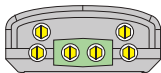

- Secondary Div. EDP** (2 possible config.)
- 1 Double port for ECAM PAS Ø5-20 (D20)
 - 4 single ports for ECAM Ø4-12 (S12)
- Or
- 6 single ports for ECAM Ø4-12 (S12)

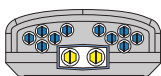

- FDP Branch** (2 possible config.)
- 1 Double port for **ECAM Double Body**
 - 10 single ports for ECAM Ø3.5-9.5 (S9.5)
- Or
- 2 single ports for ECAM Ø4-12 (S12)
 - 10 single ports for ECAM Ø3.5-9.5 (S9.5)

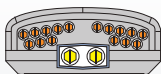

- FDP Drops** (2 possible config.)
- 1 Double port **ECAM Double Body**
 - 16 single ports for ECAM Ø3-7 (S7)
- Or
- 2 single ports for ECAM Ø4-12 (S12)
 - 16 single ports for ECAM Ø3-7 (S7)

BPE/O EVOL T1 EDP 12 pas 4 ports D4-12+1 D20 **RTSB-01-500000**

BPE/O EVOL T1 FDP Branch 12 pas 10 X S3.5-9.5 **RTSB-01-600020**

BPE-O Taille 1.5



- FDP Branch** (2 possible config.)
- 1 Double port for **ECAM Double Body**
 - 2 single ports for ECAM Ø5-18 (S18)
 - 13 single ports for ECAM Ø3.5-9.5 (S9.5)
- Or
- 2 single ports for ECAM Ø4-12 (S12)
 - 2 single ports for ECAM Ø5-18 (S18)
 - 13 single ports for ECAM Ø3.5-9.5 (S9.5)

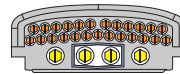

- FDP Drops** (2 possible config.)
- 1 port Double for **ECAM Double Body**
 - 2 single ports for ECAM Ø4-12 (S12)
 - 25 single ports for ECAM Ø3-7 (S7)
- Or
- 4 single ports for ECAM Ø4-12 (S12)
 - 25 single ports for ECAM Ø3-7 (S7)

BPE/O EVOL T1.5 Branch 12 pas 2 S18+13 S3.5-9.5+1 D6-18 **RTSB-01-300000**

BPE-O Taille 2 et 3

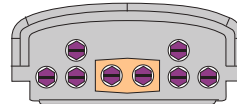

- Primary div. CDP** (2 possible config.)
- 1 Double port for ECAM PAS Ø5-27 (D27)
 - 6 single ports for ECAM Ø5-18 (S18)
- Or
- 8 single ports for ECAM Ø5-18 (S18)

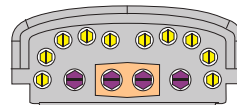

- Secondary div. EDP** (2 possible config.)
- 1 Double port for ECAM PAS Ø5-27 (D27)
 - 2 single ports ECAM Ø5-18 (S18)
 - 10 single ports ECAM Ø4-12 (S12)
- Or
- 4 single ports for ECAM Ø5-18 (S18)
 - 10 single ports for ECAM Ø4-12 (S12)

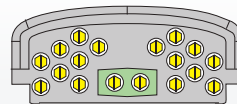

- Distribution BDP** (2 possible config.)
- 1 Double port for ECAM PAS Ø5-20 (D20)
 - 16 single ports for ECAM Ø4-12 (S12)
- Or
- 18 single ports for ECAM Ø4-12 (S12)

BPE/O EVOL T2 EDP 28 pas 2 S18+10 S12+1 D27 **RTSB-01-000021**

BPE/O EVOL T3 EDP 48 pas 2 S18+10 S12+1 D27 **RTSB-01-000051**

BPE-O Range

RANGE FIBER CLOSURE



BPE-O Size 0
48 FO - 2 liters



BPE-O Size 1
144 FO - 4.8 liters



BPE-O Size 1.5
144 FO - 5.6 liters

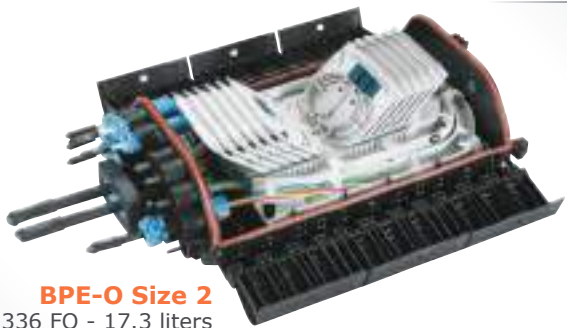

BPE-O Size 2
336 FO - 17.3 liters



BPE-O Size 3
576 FO - 23.8 liters

	BPE/O T0 equipped with ECAM Connect C1 3M + entry double 9-12 + 8 connect. SC-APC	RTSK-91-013003
	Kit BPEO T0 + 2 trays + 1 ECAM D6-18/D6-9 + Smouv	KFA-KB00-K10000N2
	Kit BPEO T1 CDP + 3 trays + 2 ECAM 5-18 + Smouv + Fixing	KGC-KC00-D20000Y2
	Kit BPEO T1.5 FDP Br. + 12 trays 9FO + 1 x ECAM D9-12/6-18 + 5 x ECAM S3.5-9.5	KHA-SL00-L1E500N2
	Kit BPEO T2 EDP 28 trays + 1 x ECAM D5-27 + 10 x ECAM S4-12 + 2 x ECAM S5-18 + Fixing	KIB-AS00-B1CJD2Y2

>>> Kits can be made according to your needs: ask us for advice!

Accessories

All accessories for BPEO can be integrated in our kittings, ask us for advice!

Kit wall fixing or pole for BPE-O T1 - plastic version	RTSB-01-000003	1
Kit wall fixing or pole for BPE-O T2/T3 - plastic version	RTSB-01-000008	

	Kit of entry BPE-O Evolution for 2 cables Ø 5 to 20 mm	RTSB-01-000154	2
	Kit of entry BPE-O Evolution for 2 cables Ø 5 to 27 mm	RTSB-01-000155	3
	Body ECAM empty - ECAM mechanical - Entry double D6-18	RTSB-01-000160	
	Cable entry kit 6 to 9 mm for body ECAM D6-18	RTSB-01-000161	
	Cable entry kit 9 to 12 mm for body d'ECAM D6-18	RTSB-01-000162	
	Cable entry kit 12 to 15 mm for body d'ECAM D6-18	RTSB-01-000163	
	Cable entry kit 15 to 18 mm for body d'ECAM D6-18	RTSB-01-000164	

	Entry kit BPE-O Evolution for 1 câble Ø 4 to 12 mm	RTSB-01-000151	4
	Entry kit BPE-O Evolution for 1 câble Ø 5 to 18 mm	RTSB-01-000152	5
	ECAM S3,5-9.5 - Single Entry for cable from 3.5 at 9,5 mm (individual bag)	RTSB-01-000124	
	ECAM S3-7 - Single Entry for cable from 3 at 7 mm (individual bag)	RTSB-01-000125	
	ECAM extended D12 - Single Entry for 4 x cables of 4 mm max	RTSB-01-000119	6
	ECAM extended D18 - Single Entry for 7 x cables of 5,5 mm max	RTSB-01-000120	

Tray 12 Fusions 1PAS for BPE-O-2	RTSB-01-100160	7
Tray 1 PAS 2 x 6 splices bi-zone G657	RTSB-01-100176	
Tray 12 universal splices 2PAS for BPE-O-2	RTSB-01-100163	8



THD FACTORY PARTNERS



RFO Range

RANGE OPTICAL FRAME

TETRADIS offers you a complete optical distribution farm including the elements of the 3M RFO product range.

Including the optical distribution frame, cable terminal, splicing/patching modules and additional accessories for an optimal optical clasp.

>> OPTICAL DISTRIBUTION FRAME RFO NG II

Optical split farms are intended for the creation of new splitters or to allow optimization or extension of existing splitters.

It consists of a beam made of aluminum profile on which will be mounted the 6, 8 or 11 cable terminal, depending on the model, through the studs pre-positioned at the factory on the front of the profile.

The rings fixed by screws and nuts or directly clipped on the profiled beam, serve to guide the cables, jumpers and cords in their vertical or horizontal path.

The labels provided in the kit will allow the identification of frames and cable heads.

MAIN DATA

- Vertical rings with curved legs
- Triple drum with increased openings
- Complete and partially assembled
- Minimum weight and space requirement

Frame RFO NG II - 6 levels 2 meters

RTST-01-001011

>> CABLE TERMINAL

The pre-wired modular cable terminal is mounted on a 6, 8 or 11 level farm.

With a capacity of 144 FO, it incorporates a device for securing and breaking the cable.

MAIN DATA

- Swivel tray marked with a label numbered from 1 to 12
- Coiling area accepting up to 2x1.6 meters of protective tubes
- Garter retention guides
- Lateral guides

Cable terminal RFO NG II - 12 trays without module

RTST-01-002020B

>> OPTICAL MODULE

Left axis module pre-equipped with 12 Pigtailed (250 μm) with 2 configurations to choose from:

- G657A2 SC / APC
- G652 D SC / APC

This module is mounted on a left axis chassis consisting of 12 trays.

MAIN DATA

- Hanging the protection tube of the fiber micro-module from the burst device,
- Management of fiber overlengths, 1 meter storage capacity for each of the 12 fibers,
- Storage rack for 12 fusion splices
- Front equipped with 12 SC / APC adapters

Module RFO-NG preco. 12 SC-APC - adapters + pigtails G657A2

RTST-01-001041

>> Available in kitting version :



RFO NG II distributor equipped with 6 levels + head + preco modules 12 adapters & pigtails SC-APC G657A2 + smouvs

RTSK-97-560002



RFO NG II distributor equipped with 6 levels + head + preco modules 12 adapters & pigtails SC-APC G657A2 + smouvs + Deecam fan-out

RTSK-97-560003



PBPO Range

RANGE OPTICAL BOX

Bearing distribution box with external drops lashing.

The bearing distribution box is the interface between the riser cable and the subscriber line cables.

Its installation is carried out on standard cables and on cables with tight stitching.

This housing has a passage zone of the vertical cable with double stowage to the right and left of the cove zone.

A zone of coiling for fibers and micromodules in passage or in waiting.

An organizer ramp 4 PAS positionable on the right or on the left, depending on the passage of the cable.

Possibility of having up to 4 trays thickness 5mm, for 12 splices by fusion by tray.

MAIN DATA

- Compact housing, sliding opening
- Symmetrical housing
- Double anchorage of the main cable
- Large zone of loorage for micromodules or fibers
- Organizer type BPEO Evolution 4 steps for 4 trays
- IP 40 and IK 08

SPECIFICATIONS

- Surface and riser mounting
- Passage of the riser cable to the right or to the left
- Stretched cable mounting, standard cable in connection with two cables
- Management of unsheathed fibers, no scrapping
- Wide possible combination of trays

CAPACITIES

From 12 to 48 FO, depending on model

DIMENSIONS (mm)

Without cover : H 204 x W 150 x D 50

With cover : H 300 x W 150 x D 50

✂	PBPO 9/125 equipped with 2 adapters & pigtails SC-APC G657	RTSK-71-022002A
✂	PBPO 9/125 equipped with 12 adapters & pigtails SC-APC G657	RTSK-71-024012A

>> Also available with connector plate for SC-PC simplex or LC-PC duplex : **PBPO-C**

Compatible only with G657 fiber.

CAPACITIES

16 ports SC Simplex or LC Duplex

✂	PBPO-C with connectors equipped with 8 adapters SC-APC + splitter PLC 1:8	RTSK-91-013002
✂	PBPO-C 62.5/125 equipped with 12 adapters and pigtails SC-PC	RIMK-70-020012
✂	PBPO-C NG 50/125 equipped with 12 adapters and pigtails SC-PC	RIMK-71-020012
✂	PBPO-C 9/125 equipped with 12 adapters and pigtails SC-APC	RIMK-71-024012





MDUO/C Range

RANG OPTICAL BOX

Housing foot box / connection of islets or quarters for 12, 24, 40 or 48 subscriber connections. Allows the interface between the network and the service.

MAIN DATA

- Versatile indoor / outdoor product
- Degree of protection: IP55 / IK06
- Materials: Thermoplastics
- Colors: (Other colors on request)
 - Light gray cover RAL 7035
 - Dark gray base RAL 7037
- Hinged lid and removable
- Available in 3 depths: 86, 116 and 156 mm
- Small dimensions and thickness
- Organizer and cassettes BPE-O Evolution
- Dielectric strength for fixing on common supports: superior to 4 kV
- Cable entry at the bottom
- Possibility of cables in transit
- Mooring and sealing for 1 to 2 feeder cables and 16 drops of subscribers

SPECIFICATIONS

- Prewiring in the factory
- Locating pigtailed at both ends
- Pigtailed waiting in cassettes
- Ends of pigtailed prepared at 250 µm
- Rack for storing unused pigtailed
- Assembly / Installation:
 - Wall: 4 screws of 6 mm (not provided)
 - Post: strapping (20 x 7 mm) on 2 supports (see accessories)

CAPACITIES

Up to 144 adapters by splices and 48 connector bases

DIMENSIONS (mm)

- MDUO 12 (BDX3000 T2B): H 400 x W 255 x D 86
- MDUO 24 (BDX3000 T2M): H 400 x W 255 x D 116
- MDUO 48 (BDX3000 T2H): H 400 x W 255 x D 156



	MDUO 12 - 9/125 equipped with 12 adapters SC-APC	RTSK-71-224012
	MDUO 12 - 9/125 equipped with 12 adapters LC-PC duplex	RTSK-71-280024
	MDUO 24 - 9/125 equipped with 12 adapters & pigtailed SC-APC	RTSK-71-324012
	MDUO 24 - 9/125 equipped with 24 adapters & pigtailed SC-APC	RTSK-71-324024
	MDUO 48 - 9/125 equipped with 40 adapters & pigtailed SC-APC	RTSK-71-324040

Accessories

The set of accessories for the MDUO/C are integrable in our kitting, ask us for advice!

Tray 1 PAS 12 splices	RTSB-01-100160
Tray 2 PAS 12 splices + 1 splitter	RTSB-01-100162
Tray 2 PAS universal 12 splices	RTSB-01-100163

Installation support for MDUO (x 2)	RTSB-70-000029
-------------------------------------	-----------------------

Measurement instrumentation

RANGE OPTICAL FIBER MEASURE

EXFO is the world leader in portable optical solutions. With 40% of revenues generated by products less than 2 years old, **EXFO** shows its involvement in innovation.



MaxTester DSL

Portable device designed to test ADSL2 + and VDSL2 connections.



MaxTester OTDR

Reflectometer for short-range networks, FTTx or point-to-point access networks. Can work as a conventional reflectometer or in iOLM mode for detailed link analysis automatically.



FTB-1 iOLM

Portable modular platform optimized for fast, powerful and dedicated FTTH or Ethernet tests.



FTB-2 PON iOLM

High-end compact platform for multi-network, multi-technology and multiservice testing.



Fiber Guardian

Scalable test solution for monitoring and managing a fiber network from a stand-alone unit to centrally managed systems with one or hundreds of test ports.

MaxTester DSL	Nous consulter
MaxTester OTDR	Nous consulter
Kit FTB-1 iOLM with module FTB730 + Fast reporter + video probe FIP-430B + guaranteed extension	MTSI-15-100001
EXFO FTB-200 modular compact platform with color touch screen	MTSI-12-000200
Fiber Guardian	Nous consulter

iOLM: FO certification...



Complete parameter configuration and complex OTDR trace analysis.

The iOLM adapts dynamically to all fiber links and correlates multi-pulse widths over many wavelengths to help you locate and identify faults with maximum resolution.





Video inspection FIP-400

RANGE OPTICAL FIBER MEASURE

The FIP-400 is an inspection probe for detecting dirty or damaged connectors with unmatched accuracy. It is available in "portable screen" version or USB adapter, for viewing on a PC.

The probe can also be connected to the AXS-200, FTB-200, FTB-400, the AXS-100 reflectometer and the FOT-930 automatic photometer.

MAIN DATA

- Magnification 200x and / or 400x
- Inspection of connectors installed in a patch bay
- Image capture
- Compatible with all types of connectors, in PC and APC version.
- Elongated shape for easy work in brewing bays
- Compatible with Exfo test instruments
- USB adapter (PC connection) or independent display screen
- Compatible with ConnectorMax analysis software
- Available connectors: ST, FC, SC, LC, MU, E-2000
- Easy inspection of rear panel connectors
- Robust and lightweight, perfect for field testing
- Image capture for end of production reports
- Ideal with all types of connectors: APC, UPC, MTP, etc.
- Slim housing for easy use in congested distribution panels
- Compatible with EXFO test devices

APPLICATIONS

- Inspection of connection cables
- Inspection of connectors in distribution panels
- Single Fiber Connector Inspection: Compatible with 1.25 and 2.5mm APC and UPC connectors
- Multi-fiber connector inspection: Compatible with both male and female ribbon connectors, such as APC and UPC multifiber MTP connectors



FIP-400 - Video Inspection Probe + 3.5" TFT Monitor + FC-SC Adapter	MTSI-20-000400
Adapter kit for 1,25 mm ferrule	MTSI-20-001001
Adapter kit for 2,5 mm ferrule	MTSI-20-001002
Adapter SC-APC	MTSI-20-001024
Adapter USB2 & Pc software	MTSI-20-001095

Optical inspection probe

RANGE OPTICAL FIBER MEASURE

With the P5000i, it is quick and easy to certify that each optical connection in your network is optimized.

This optical connector inspection microscope eliminates interpretation errors and provides an objective and reliable pass / fail result. It thus guarantees your network for an optimal user experience.

MAIN DATA

- Automatic SUCCESS / FAIL analysis eliminates any subjectivity in the measurement process
- User-definable compliance profiles allow certification to be based on any criteria
- Includes FiberChekPRO™ software for analysis and reporting from a PC / laptop
- The fiber is always centered on the screen thanks to the automatic centering of the image
- Both magnifications allow you to switch between high and low magnification, both in real time and during the analysis
- Compatible with SmartOTDR, MTS-2000/4000/5800 / 6000A / 8000v2, HST-3000, SMART-Class™ Fiber, Certifier40G, DSAM and CellAdvisor via USB port without the use of an adapter or additional software.
- Compatible with Android™ tablets / smartphones with the FiberChekMOBILE app (available on Google Play). FiberChek MOBILE enables you to inspect and certify industry-standard optical connectors directly from your handheld. The application also measures the optical power.

P5000i Digital Probe Pack + Software + 7 Adapters + Satchel	MTSI-11-000151
---	-----------------------



Splicing by fusion

RANGE OPTICAL SPLICERS

Fusion splicing is the guarantor of an honest, efficient and durable optical connection. To respond to different markets, **Fujikura** has developed 3 products of excellence in their respective fields.

FSM 12S

- **Perfect for FTTH**
- 2-axis alignment
- Storage of the last 3000 splicing results in memory
- Cleavage length from 5 mm to 13 mm
- Visualization / magnification method: 2-axis CMOS camera and 11.35 cm LCD color screen. Magnification 100 times
- 60 mm, 40 mm heat-shrink sleeves and Fujikura micro-sleeves
- H 57 x W 121 x D 162
- Weight with battery: 776 g



Pack FSM 12S + cleaver CT30 + battery and accessories

OTSK-10-000112

FSM 22S

- **Versatile**
- Dynamic alignment of fibers on **3 axes**
- Storage of the last 10,000 splicing results in memory
- Cleavage length from 5 mm to 16 mm
- Visualization / magnification method: 2 CMOS cameras and 12 cm LCD screen. Magnification x132 before welding / x200 after welding
- 60 mm, 40 mm heat-shrink sleeves and Fujikura micro-sleeves
- H 72 x W 120 x D 189
- Weight with battery: 1140 g



Pack FSM 22S + cleaver CT30 + battery and accessories

OTSK-10-000122

FSM 70S+

- **Productivity and performance**
- Bluetooth connectivity
- Dynamic alignment of fibers on **3 axes**
- Storage of the last 2,000 splicing results in memory
- Cleavage length from 5mm to 16mm with jaws (sheath locks)
- Display / Magnification Two CMOS cameras and 12 cm color LCD screen. X / Y (Magnification 320X), or simultaneously X and Y (Magnification 200X)
- 60 mm, 40 mm heat-shrink sleeves and Fujikura micro-sleeves
- H 150 x W 146 x D 159
- Weight: 2.5 kg (with ADC-18 AC adapter)
- Weight: 2.7 kg (with BTR-08 battery)



Pack FSM 70S+ with cleaver CT30 + battery BTR-08L + patchcord

OTSK-10-000170

For your splicing operations,
think of the tools TETRADIS !



Liftplaq®

RANGE TOOLING

The **LIFTPLAQ®** is a handling tool allowing the handling of plates and buffers dedicated to professionals of dry and wet networks.

This system, equipped with a lever arm with a powerful magnet, allows to unhook the plates without touching them and reduces the difficulty by three.

The **LIFTPLAQ®** comes in the form of a tool consisting of a mechanical assembly. It is provided with a magnetic device allowing the firm gripping of the plates and the displacement of these. This tool is usable for dry and wet networks.

MAIN DATA

- Easily and effectively lift plates or pads SAFELY thanks to its powerful magnet
- Supplied with 1 counterweight on the body (for storage) or on the handle (for mass use)
- Permanent super-powerful magnet not subjected to periodic inspections
- Wheels close together as standard (20 cm spacing)
- Can be optionally equipped with 2 55 cm wheel extensions (110 cm center distance)
- With wooden transport shoe for transporting **the LIFTPLAQ®** in a vehicle with a metal floor without being magnetized
- Color: yellow and red

EASE OF USE

Lay the magnet on the manhole cover, lift and move easily while driving. Remove the very powerful magnet by unhooking the handle and simply lifting on the other side.

SECURITY

It allows the user to be safely assisted during Entry / Lift / Move / Drop / Rest operations. (System rewarded at the 15th crossroads health and safety at work)

APPLICATION

Magnetic buffer lifter used by all stakeholders VRD / BTP / Telecom. Adaptable to all types of telecom plates and road buffer.

DIMENSIONS (mm)

Height 500 x Length 1000
 Width with standard castors: 200
 Width with wheel extender: 1100
 Weight 18 kg

PATENTED SOLUTION



LIFTPLAQ® lifter + chisel + 1 mass bronze + handle	PTXX-09-000030
Pair of wheel extensions 110 cm (2 x 55 cm)	PTXX-09-000031

>>> Also available in Mini LIFTPLAQ®

MAIN DATA

- Easily and efficiently lift plates or buffers of small size in SECURITY thanks to its powerful magnet (announced for 40 kg according to legislation)
- Adjustable handle
- Permanent magnet not subject to periodic inspections
- Red color

DIMENSIONS (mm)

- Height 470 (retracted sleeve)
- Height 850 (handle left)
- Width of handles 310
- Magnet Ø110
- Weight 3.5 kg

MINI-LIFTPLAQ®	PTXX-09-000040
----------------	----------------



Nomenclature

- 1 - Handle that can receive the bronze feeder
- 2 - Bronze feeder to screw on the handle of the handle
- 3 - Removable and adjustable handle
- 4 - Body of the device
- 5 - Articulated arm
- 6 - Cotter pin with chain (locking of the articulated arm in use)
- 7 - Magnet
- 8 - Handle adjustment pin
- 9 - Handle used as crutch and to release the magnet from the plate
- 10 - Wheels
- 11 - Wheel assembly pin
- 12 - Chisel tip at end of sleeve
- 13 - Transport shoe
- 14 - Wheel extension (optional)

On all types of plates



Works on all types of plates, including partially concreted plates

Fixing accessories overhead networks

RANGE TOOLING

ANCHORING CLAMP

- Thermoplastic protected U.V
- Stainless steel
- Automatic conical clamping
- Fast opening cable to install
- Bearing Ø capacity on sheath:
 - Model PA 35: 3-5 mm
 - Model PA 57: 5-7 mm
 - Model PA 69: 6-9mm
- Different cable length available: 120, 200, 300 mm
- Maximum installation voltage:
 - Model PA 35: 70 daN
 - Model PA 57: 120 daN
 - Model PA 69: 120 daN

Anchoring clamp Ø5-7.5mm, cable length 200mm - PA57200	PGXX-41-305200
Anchoring clamp Ø5-7.5mm, cable length 300mm - PA57300	PGXX-41-305300
Anchoring clamp Ø6-9mm, cable length 200mm - PA69200	PGXX-41-306200



ANCHORING CLAMP FOR ROUND OPTICAL CABLE

- Thermoplastic protected U.V
- Stainless steel
- Automatic conical clamping
- Specific corners to minimize cable compression stress
- Fast and easy-to-install captive cable
- Mechanical resistance depending on the type of cable, climatic conditions and installation.
- Bearing Ø capacity on sheath: 8-10mm. Other capacities on request.
- Different cable length available: 200 or 300 mm

Anchoring clamp FO cable Ø8-10mm, cable length 200mm - PAFO200D8-10	PGXX-41-200810
---	-----------------------



SUSPENSION CLAMP

- Fixing on hook or pigtail console Ø max. 16 mm, 1 bolt Ø 16 mm or 2 strips of stainless steel strip 20 mm.
- Fusible throttle option : allows clamping of the pliers without tools. The throttle valve controls the tightening torque of the nut.
- Installation limit: up to a deflection angle of 25°
- Capacity Ø6-15mm. Other capacities on request.
- Minimum tensile strength vertical: 300 daN
- Weight: 0.375 kg

Suspension clamp Ø6-15mm - PS615ADSS	PGXX-41-606000
--------------------------------------	-----------------------



EXTENSION KIT FOR TELECOM POLE

- Allows the deployment of an optical fiber mat on an existing telecom pole, above the layer of copper cables.
- Adaptable on wood or metal pole, inside a bollard or a Lorraine mat.
- Thanks to its 11 fixing holes placed on the two edges, it can be installed either in front of the existing armaments, or perpendicular according to the space available and facilities of fixings.
- The mounting plate of the cross member is stable and compatible with hole spacings from 40 mm to 60 mm (5/14, 5/15 or 5/19 crossbar).
- The use of optional flanges RPT 15 B ensures a robust attachment by strap and makes it possible to move the extension from the pole to straddle a collar for example.

Extension kit with flanges - RPTCB KIT	PTXX-01-911111
Extension kit wood pole	RTSK-97-000043



Accessories

Cross INOX - length 440 mm - TRAV514	PTXX-01-911020
Cross INOX - length 1090 mm - TRAV519	PTXX-01-911025
Strip INOX 200mm*0,7 - roll of 25m	RTSK-97-500011



Markers detector 1420^E

RANGE COPPER MEASURE

New marker locator with the ability to write, read, and lock programmed information to the next generation EMS-ID marker. It detects any type of existing markers.

MAIN DATA

- Very robust, ergonomic, easy to handle and easy to use
- Large backlit display and clear function keys
- Complete system that fits in the hand

SPECIFICATIONS

- Microprocessor assisted system
- Uses the latest digital signal processing techniques
- Locates both traditional passive markers and EMS-ID marker balls
- Able to locate and process two different types of network markers simultaneously

APPLICATION

- Used to locate the location and depth of EMS and EMS-ID buried markers
- Allows you to locate, read and write in EMS-ID markers equipped with a memory chip data such as:
 - the serial number (predefined unique identification number), the owner,
 - Installation details, data about public networks, the type of application,
 - the date of implementation, and many others, ...
- to transfer them to your computer or GPS / GIS devices via an interface - for automatic registration of positions in CAD or GIS programs



Markers detector EMS and EMS-ID with writing - 1420E

MTCX-08-001200

Markers EMS and EMS-ID

EMS and EMS-ID surface markers

1

- Ideal for marking underground pipes and pipelines to a depth of 0.61 m
- Cylindrical
- Its size allows it to be easily laid in asphalt, cement, without trenching or expensive drilling
- Dimensions (mm) Ø16 x W 89
- Packaged in packs of 50
- Also available for other networks (Consult us)



Surface marker EMS (1432) - Orange - Telecom (x 50)	Nous consulter	1
Surface marker EMS-ID (1432) - Orange - Telecom (x 50)	PTXX-20-000120	

>>> Others models, consult us

EMS and EMS-ID marker balls

3

- Designed for narrow trenches up to 1.22 m deep
- Features a unique patented self-leveling device that provides a precise horizontal position regardless of how the ball is placed in the ground
- Dimensions (mm) Ø 102
- Packaged in packs of 30
- Also available for other networks (Consult us)



Marker ball EMS (1402) Orange Telecom (lot de 30)	PTXX-20-000041	2
Marker ball EMS-ID (1421) Orange Telecom (lot de 30)	PTXX-20-000140	3

>>> Others models, consult us

Mini EMS markers

4

- Designed for marking at depths up to 1.83 m
- The branches of the mini marker make it possible to stabilize it in the correct position after its placement
- Dimensions (mm) Ø 210
- Packaged in packs of 50
- Also available for other networks (Consult us)
- Not available in 'ID' version



Mini EMS marker (1255) Orange Telecom (x 50)	PTXX-20-000030	4
--	-----------------------	---

>>> Others models, consult us

Maxi markers EMS and EMS-ID

6

- Suitable for applications ranging from up to 2.43 m deep
- Ideal for locating underground networks of great depth
- Dimensions (mm) Ø 381
- Packaged in packs of 25
- Also available for other networks (Consult us)



Maxi marker EMS (1250) Orange - Telecom (lot de 25)	Consult us	5
Maxi marker EMS-ID (1250) Orange - Telecom (lot de 25)	Consult us	6

>>> Others models, consult us

Respect the environment

Marker balls have a high density, waterproof, polyethylene outer shell, which is impervious to the attack of minerals, chemicals and temperature normally found in the underground environment. They contain a mixture of propylene glycol and water, in accordance with the uses in pharmaceuticals, cosmetics, or as a food additive, making it an easily biodegradable mixture that does not harm humans, wildlife or animals. environment.



NOTES

A large area of the page is filled with horizontal dotted lines, providing a space for handwritten notes.



GLOSSARY

A

ADAPTER

Mechanical element making it possible to make a connection between two plugs.

B

BACKBONE

Network section with the highest traffic load

C

CABINET

Box for connecting communication cables, distribution and connection equipment, with a swinging cover.

Cabinet (distribution): closed space containing all communication equipment, cable connections and splitter boxes. This is the recognized distribution location between vertical and horizontal distribution.

CLEAVER

Tool to break the fiber (cleave) and prepare for splicing.

COILING

Loop cable serving as reserve in case of re-intervention.

D

DTI

"Interior Termination Device", means the box serving as a border between the Telecom network and the customer's telephone network. This housing, also called Terminal or Subscriber Box, is installed at home.

DTI-O

"Optical Interior Termination Device", same as DTI in Optical version.

E

ETSI

"European Telecommunications Standards Institute", European standardization body in the field of telecommunications.

19" contra bay standard.

F

FERULE

End of a connector inside which the fiber is located.

FIBER SPLICE CLOSURE

Generally refers to any type of fiber optic junction box installed on the structuring part of the feeder network, either to divert fibers to buildings or to break up a transmission cable to distribution cables.

FIST

« Fiber Infrastructure System Technology »

FTTH

« Fiber To The Home » : a physical telecommunications network that notably allows very high-speed internet access and in which the optical fiber ends at the subscriber's home.

FTTO

« Fiber To The Office » : privileged by small businesses, SMEs and communities whose connectivity is essential to the smooth running of their business to access for example remote services that are greedy.

I

IK

The IK index determines the degree of protection of the equipment against mechanical shocks. (examples: IK08, IK09, etc ...)

IL

Insertion Loss

L

LAN

Network with limited right-of-way (from a few hundred meters to a few kilometers).

M

MAN

" Metropolitan Area Network " refers to a network of computers usually used in campuses or in cities. The network generally uses fiber optics.

O

OPTICAL FAN-OUT

Device allowing a new arrangement of the optical fibers contained in one or more optical fiber cables to one or more other optical fiber cables of different modularity or different destination (for example: fiber optic cable dedicated to different operators; a riser).

P

PATCHCORD

Cable or cord without connector used for connection to a splitter box.

PIGTAIL

Fiber of 900µm of a few meters, preconnectorized at one end and intended to be connected at the other end by a splice.

R

REFLECTOMETER

Measuring device for verifying that an optical transmission line is mismatched (measurement of optical budget, length, reflection).

THE ACCOMPANYING FOR ALL YOUR PROJECTS

FTTH SOLUTION

Introducing an **optical fiber network** as it could be deployed by a collectivity or in a big town, by a telecom operator.

Each product is so detailed, from the outdoor street cabinet to the buried fiber closure, but also component as splicing shelves, cables and outdoor boxes, it is a question of proposing a complete solution dedicated to the very high speed.

DATACENTER SOLUTION

This solution highlights the products needed for **datacenter installation**, by an operator or for a company.

We thus find indoor cabinets, active equipments, splicing shelves and cabling equipment. An optimal solution for a performing datacenter.

VDI SOLUTION

Destined to a tertiary use, the products proposed in the **VDI solution** will allow the telecom installer or the electrician to link the final customer to the multiple network connections needed, telephony, internet or other. RJ45 plugs, electric powerstrips, cabinets and indoor computer cases which are proposed perfectly fit within industrial and tertiary deployment.

SECURITY SOLUTION

Through this **security solution**, a private company, a public establishment or an installer would have all the video protection equipment, access control and intrusion detection to equip buildings.





1, RUE DU MOLLARET
 PARC D'ACTIVITÉ DE CHESNES
 38070 SAINT QUENTIN FALLAVIER
 TÉL. +33 (0)4 74 95 39 95
 FAX. +33 (0)4 74 95 39 89
 EMAIL. CONTACT@TETRADIS.COM

